

V-SCADA2000 Product Series

The cross platform SCADA system



V-SCADA2000 Product Series

V-SCADA2000 Veesta SCADA Control System 2000 Product Series

Overview

V-SCADA2000 Series consist of many Supervisory Control And Data Acquisition system and advances system applications adopted for from very small system as like of production line automation and substation automation that can be used in small scale application up to very large system as regional dispatch center and area operating control center, as like of Power grid SCADA control center, Oil & Gas monitoring system Electric grid distribution control and other utilities like water and wastewater enhanced control function.

Concept

- Provide a solution based on a flexible and state of the art architecture, being able to:
 - Execute real time control and supervision functions
 - Execute studies
 - Execute advanced applications
- The outcome of this concept is to be applied in electric power networks management

Basic Principles

- Open Systems
- Object Orientation
- Distributed Architecture (render to the Server what is due to the Server)
- Industrial and International Standards
- User Friendly (for engineers and operators)
- Modular, suitable for Upgradeable Solutions

Adopted Standards

- Operating Systems
 - Microsoft Windows, UNIX, LINUX
- Windows Look-and-feel
 - Multi Platform, QT Interface
- Downstream Protocol
 - IEC 60870-5-101, IEC 60870-5-104, DNP 3.0, Modbus, IEC61850
- Inter-Control Centre Protocol
 - Under development of IEC 60870-6 (TASE.2 / ICCP), OPC
- Inter-Application Protocols
 - TCP / IP
- CORBA, for the system architecture
- SQL for the Any Relational Database like ORACLE

V-SCADA2000 Open Standards

V-SCADA2000 Open Standard Design

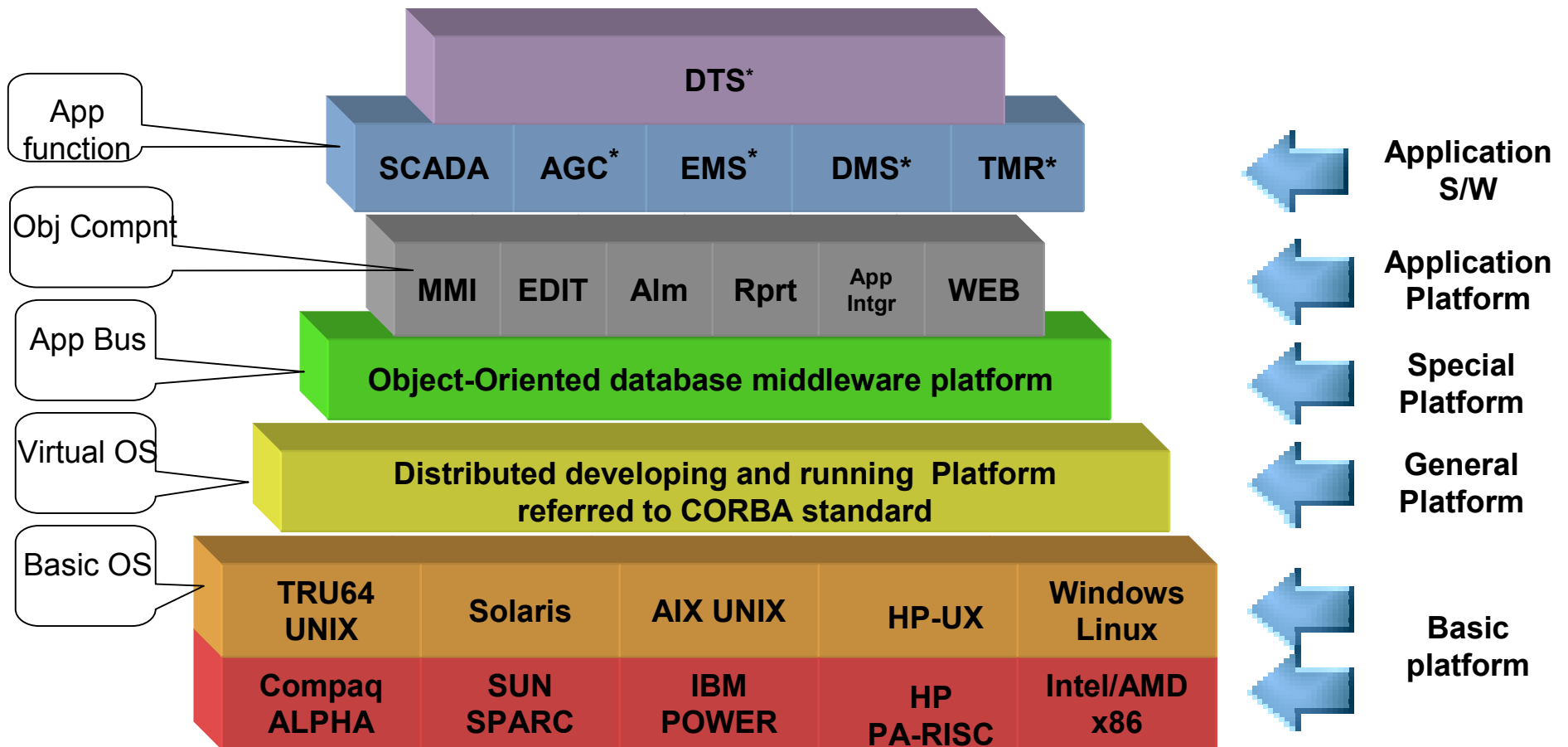

V-SCADA2000 Open Standards

V-SCADA2000 Software Bus Design

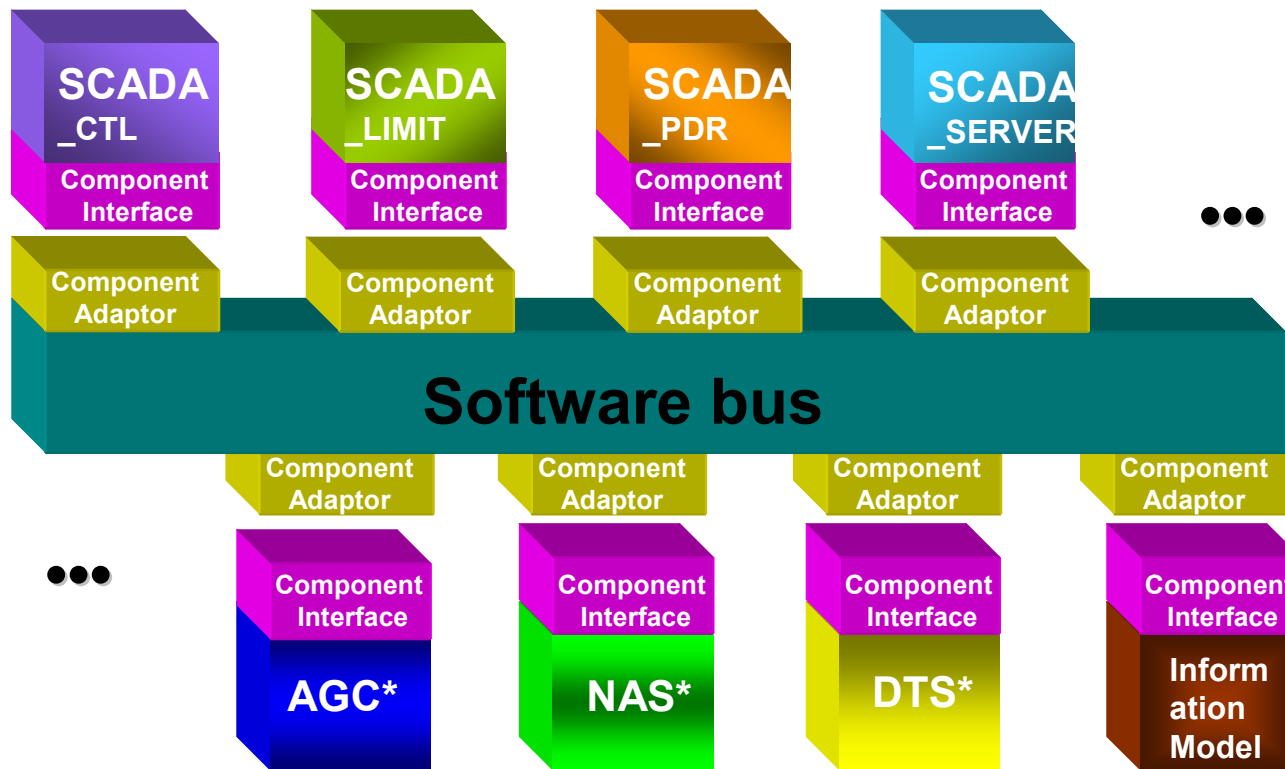

Software Componentization is the base for PLUG and PLAY

V-SCADA2000 Architecture

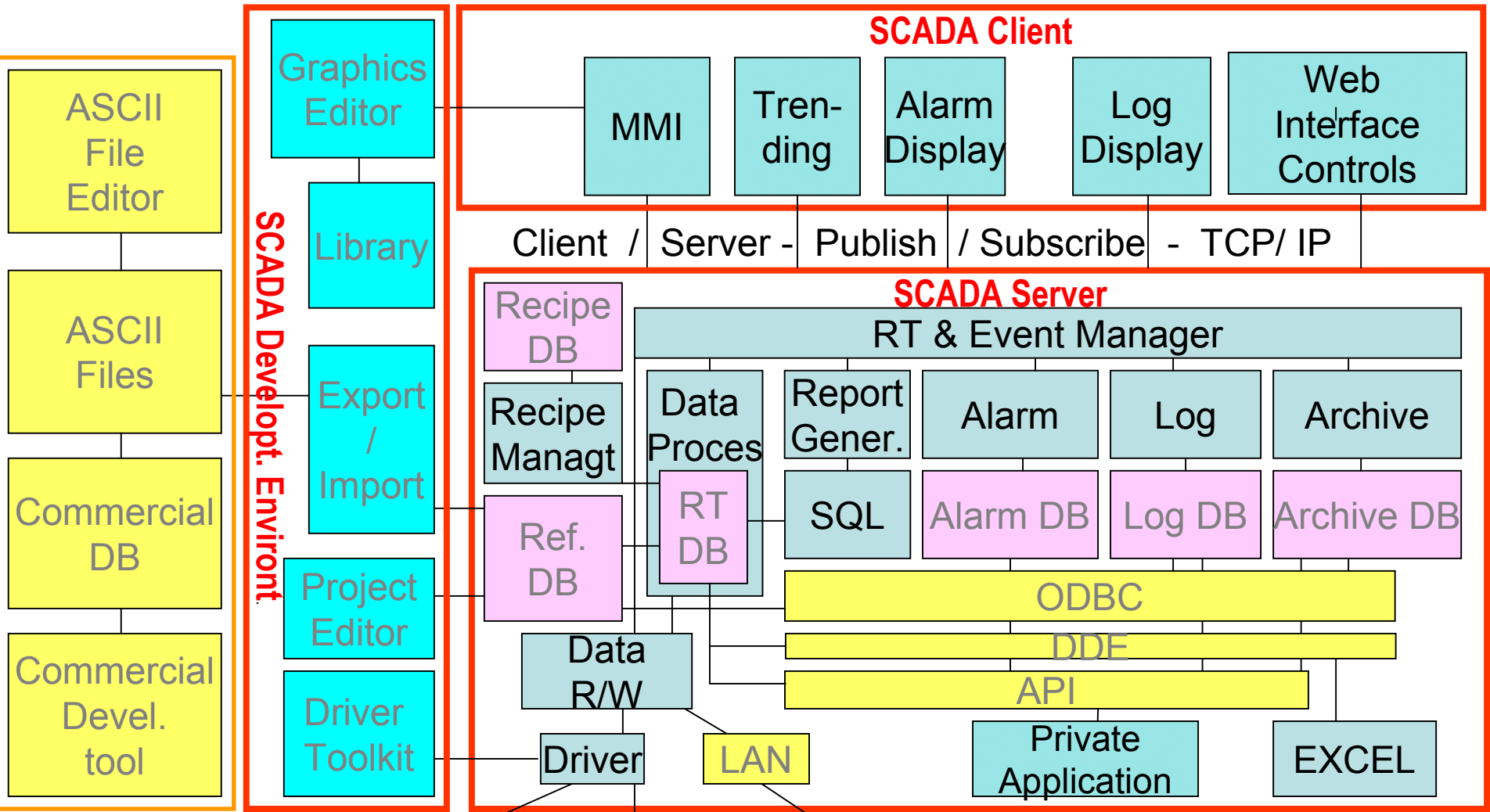

8 IEC101, IEC104, DNP3.0, Modbus

RTUs

Other Centers



V-SCADA2000 Components

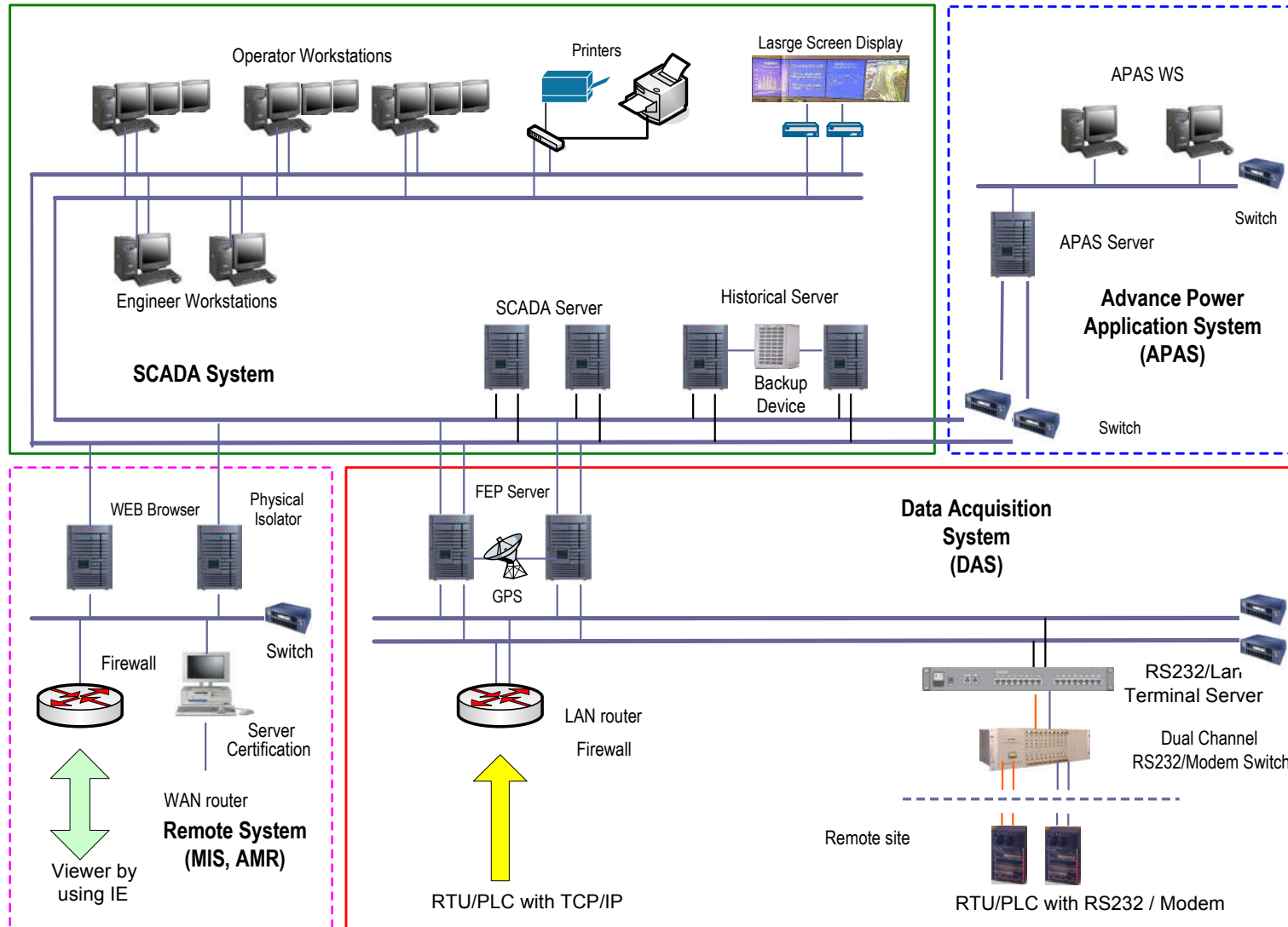

SCADA Features

V-SCADA2000 Main Characteristics

- Remote Control and Data Acquisition
- Graphical User Interface
- Alarms Management
- Redundant Servers, Front-ends & LAN (optional)
- Videowall + Image Manager
- Remote Workstations
- Remote Communication Front-ends

SCADA Features

V-SCADA2000 Main Characteristics

- Access Control: Password & Responsibility Areas
- Online Configuration and Maintenance
- User Defined Reports
- User Programmable Applications

SCADA Features

V-SCADA2000 Main Characteristics

- **Digitals**
- **Analogues**
- **Counters**

Have

- Descriptions
- Time & Date
- State / Status
- Notes & Tags

SCADA Features

V-SCADA2000 Main Characteristics

- **Digitals**
- **Analogues**
- **Counters**

Generate

- **Calculated Data**
- **Events**

- **Descriptions**
- **Time & Date**
- **State / Status**
- **Notes & Tags**

SCADA Features

V-SCADA2000 Main Characteristics

- **Digitals**
- **Analogues**
- **Counters**

- Calculated Data
- Events

Generate

- Descriptions
- Time & Date
- State / Status
- Notes & Tags

- Alarms

Generate

- **Controls, Sequences**

SCADA Features

V-SCADA2000 Main Characteristics

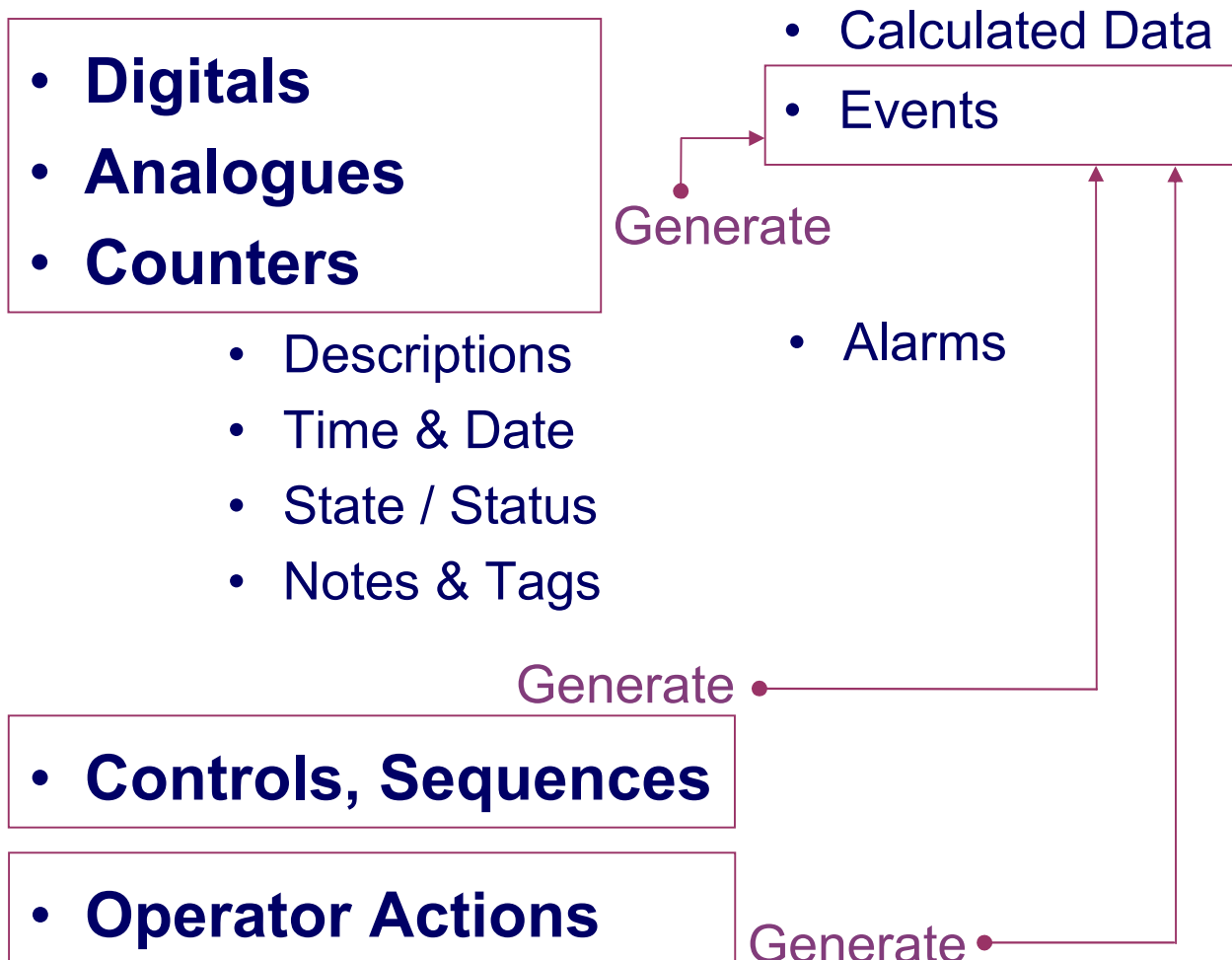

SCADA Features

V-SCADA2000 Main Characteristics

- Digitals
- Analogues
- Counters
- Calculated Data
- Events

- Descriptions
- Time & Date
- State / Status
- Notes

- **Alarms**

Have



- Controls, Sequences
- Operator Actions

SCADA Features

V-SCADA2000 Main Characteristics

- Digitals
- Analogues
- Counters
 - Descriptions
 - Time & Date
 - State / Status
 - Notes
- Controls, Sequences
- Operator Actions
- Calculated Data
- Events
- **Alarms**
 - Result from
 - Variations (ΔV , $\Delta V / \Delta t$)
 - Validity status
 - Limits (VH, H, L, VL)
 - Controls Execution

SCADA Features

V-SCADA2000 Schematic Diagrams

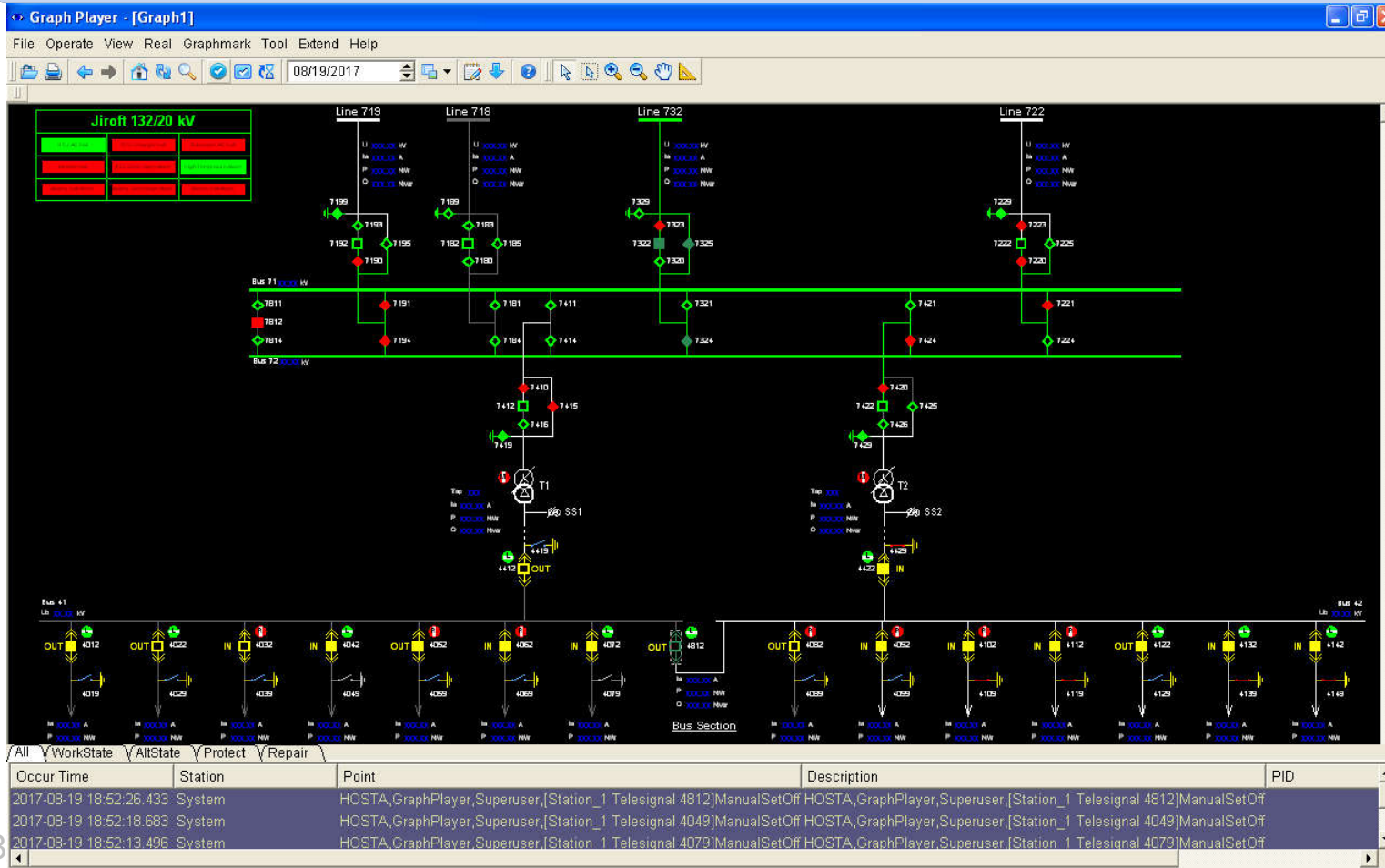

SCADA Features

V-SCADA2000 Schematic Diagrams

The screenshot displays the V-SCADA2000 Graph Player interface. The title bar reads "Graph Player - [C:/scada_root/graphlocal/projects/main.grh]". The menu bar includes "File", "Operate", "View", "Real", "Graphmark", "Tool", "Extend", and "Help". The toolbar contains various icons for file operations and navigation, with a date of "06/30/2013" displayed. The main window shows a "Substation SCADA System Project Samples" menu with the following options:

- SB-003 Line diagram
- SB-004 Line diagram
- SYS Architecture
- Bar Chart
- Curve Chart
- Report forms
- Analog Realtime Info
- Digital Realtime Info
- Other Realtime Info

Additional information on the right side of the menu includes "Current Time: 21:24:28" and "Safety Run: 2099 Days". The interface also features a decorative graphic of a substation tower and a vertical stack of four images showing different views of a substation.

SCADA Features

V-SCADA2000 User defined Diagrams

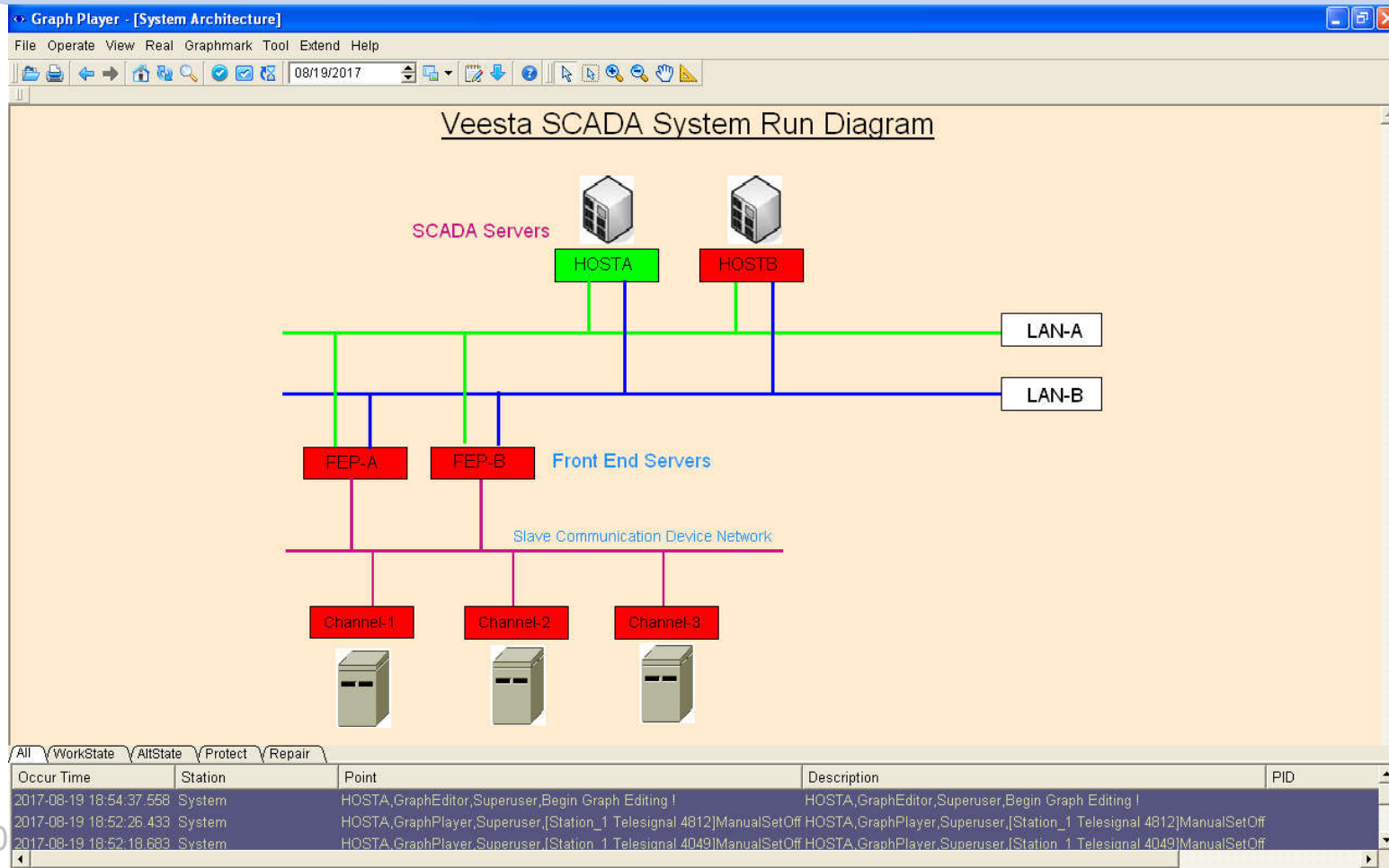

SCADA Features

V-SCADA2000 Trend Display in Schematic Diagrams

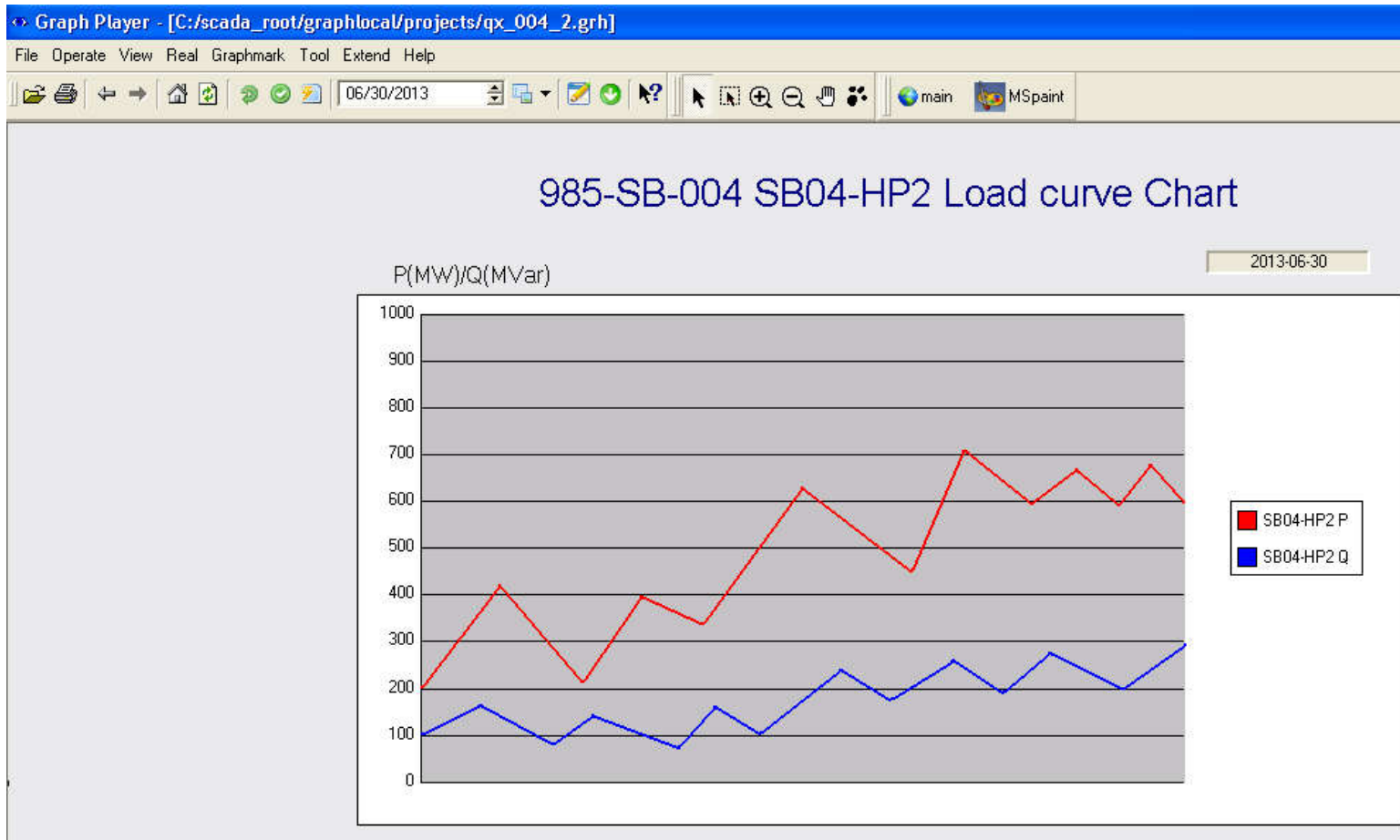

SCADA Features

V-SCADA2000 Archived Trend Display

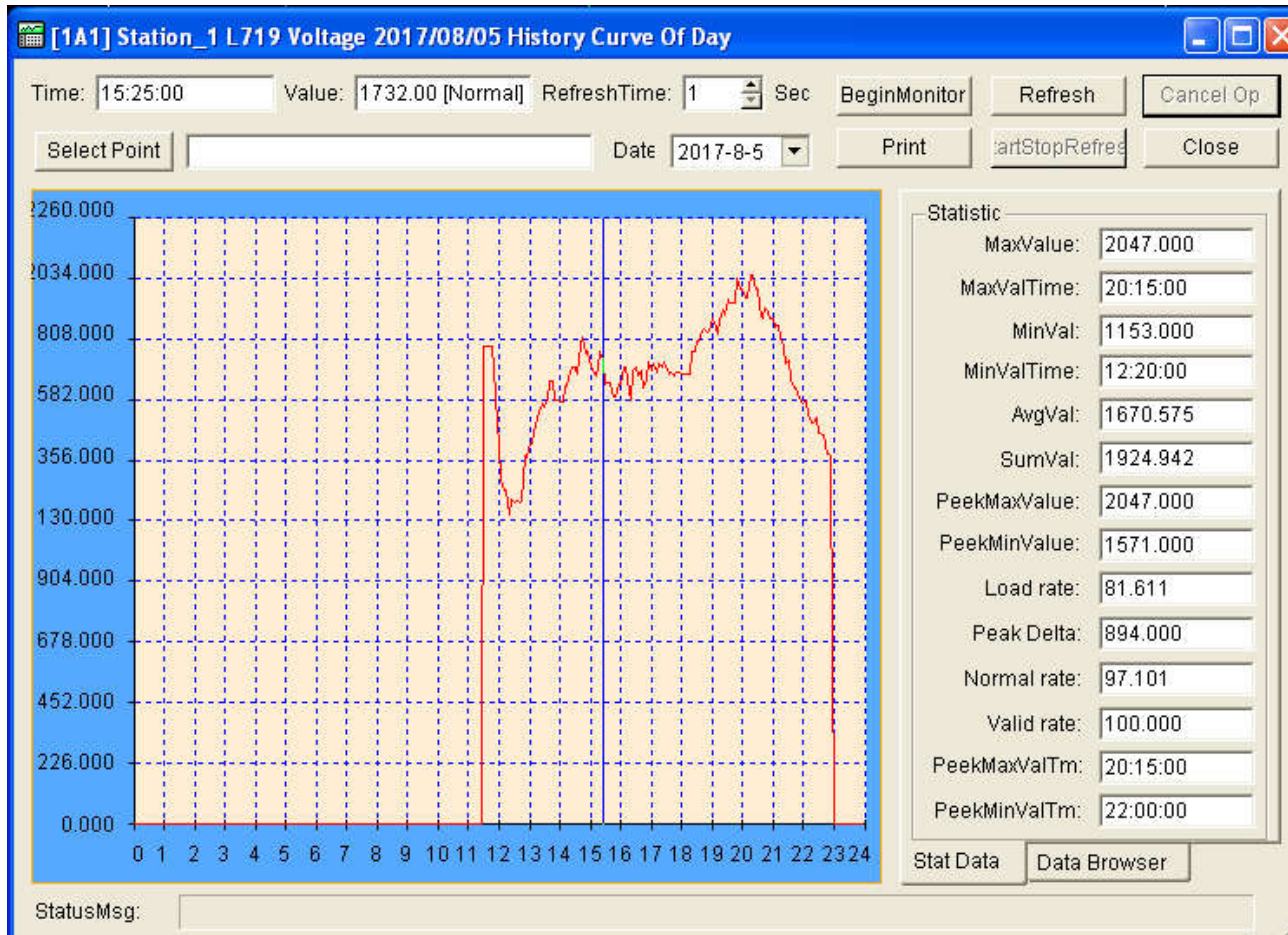

SCADA Features

V-SCADA2000 Starting Control Bar

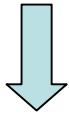

Click on
Start Menu bar



SCADA Features

V-SCADA2000 Alarm List

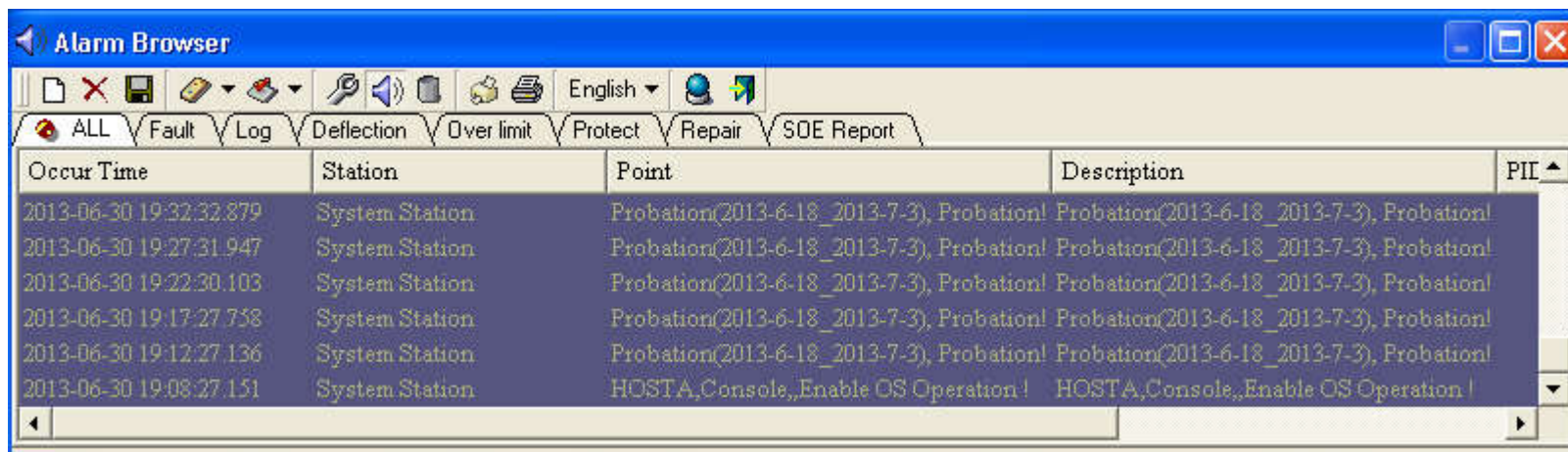

The screenshot shows the 'Alarm Browser' window with a toolbar and a table of alarm events. The toolbar includes icons for file operations, search, and language selection (English). The table has columns for Occur Time, Station, Point, Description, and PII. The data rows show multiple 'Probation' alarms for 'System Station' and one 'HOSTA,Console,Enable OS Operation!' alarm.

Occur Time	Station	Point	Description	PII
2013-06-30 19:32:32.879	System Station	Probation(2013-6-18_2013-7-3), Probation!	Probation(2013-6-18_2013-7-3), Probation!	
2013-06-30 19:27:31.947	System Station	Probation(2013-6-18_2013-7-3), Probation!	Probation(2013-6-18_2013-7-3), Probation!	
2013-06-30 19:22:30.103	System Station	Probation(2013-6-18_2013-7-3), Probation!	Probation(2013-6-18_2013-7-3), Probation!	
2013-06-30 19:17:27.758	System Station	Probation(2013-6-18_2013-7-3), Probation!	Probation(2013-6-18_2013-7-3), Probation!	
2013-06-30 19:12:27.136	System Station	Probation(2013-6-18_2013-7-3), Probation!	Probation(2013-6-18_2013-7-3), Probation!	
2013-06-30 19:08:27.151	System Station	HOSTA,Console,Enable OS Operation!	HOSTA,Console,Enable OS Operation!	

- Entity Alarms (analogues, digitals, counters)
- Alarms for Controls and Sequences of Controls
- Operator Actions: Acknowledgement and Deletion
- Configurable Colours for Alarms Meaning

SCADA Features

V-SCADA2000 Graph and Schematic Editor

The screenshot displays the V-SCADA2000 Graph and Schematic Editor interface. The main workspace shows a schematic diagram of a 230kV line with various components labeled: FES31, DS32, ES32, CB31, ES31, DS31, and ES21. A central transformer is labeled '230kV LINE'. The interface includes a menu bar (File, LayerManage, Edit, Operate, View, Tools, Extend, Window, Help), a toolbar, and several panels:

- LayerStructure:** Shows 'S000_Sample' and 'NewLayer1'.
- Properties Panel (ElectricBreak - ElectricBreak57):**

Properties	Value
Name	ElectricBreak57
Description	
IsPowerPoint	false
VoltGrade	Invalid VoltGrade
DevDescription	
Off_Symbol	sudan_cb_off_1
On_Symbol	sudnahe
OffInvalid_Symbol	symbol33
OnInvalid_Symbol	symbol34
OffFlash_Symbol	sudan_cb_off_2
OnFlash_Symbol	symbol32
OffManualSet_Sym...	symbol33
OnManualSet_Sym...	symbol34
RefreshBackground	true
- IconLib:** A library of symbols including IconLib_Break, IconLib_Capacitor, IconLib_Generator, IconLib_GroundSwitch, IconLib_LoadDevice, IconLib_OtherDevice, IconLib_Reactor, IconLib_Switch, IconLib_TransformerWinding, and Labels_Bypass.
- Properties Panel (Ia, P, Q):**

Ia XXX.XX A
P XXX.XX MW
Q XXX.XX Mvar

P ↓
Q ↓
- Right Panel:** A grid of various electrical symbols for selection.

The status bar at the bottom shows: Ready, SelectLayer: NewLayer1, Zoom: 5.3893, MouseLocate: -51.6346, 82.1495KileMeter.

SCADA Features

V-SCADA2000 Dynamic Network Coloring

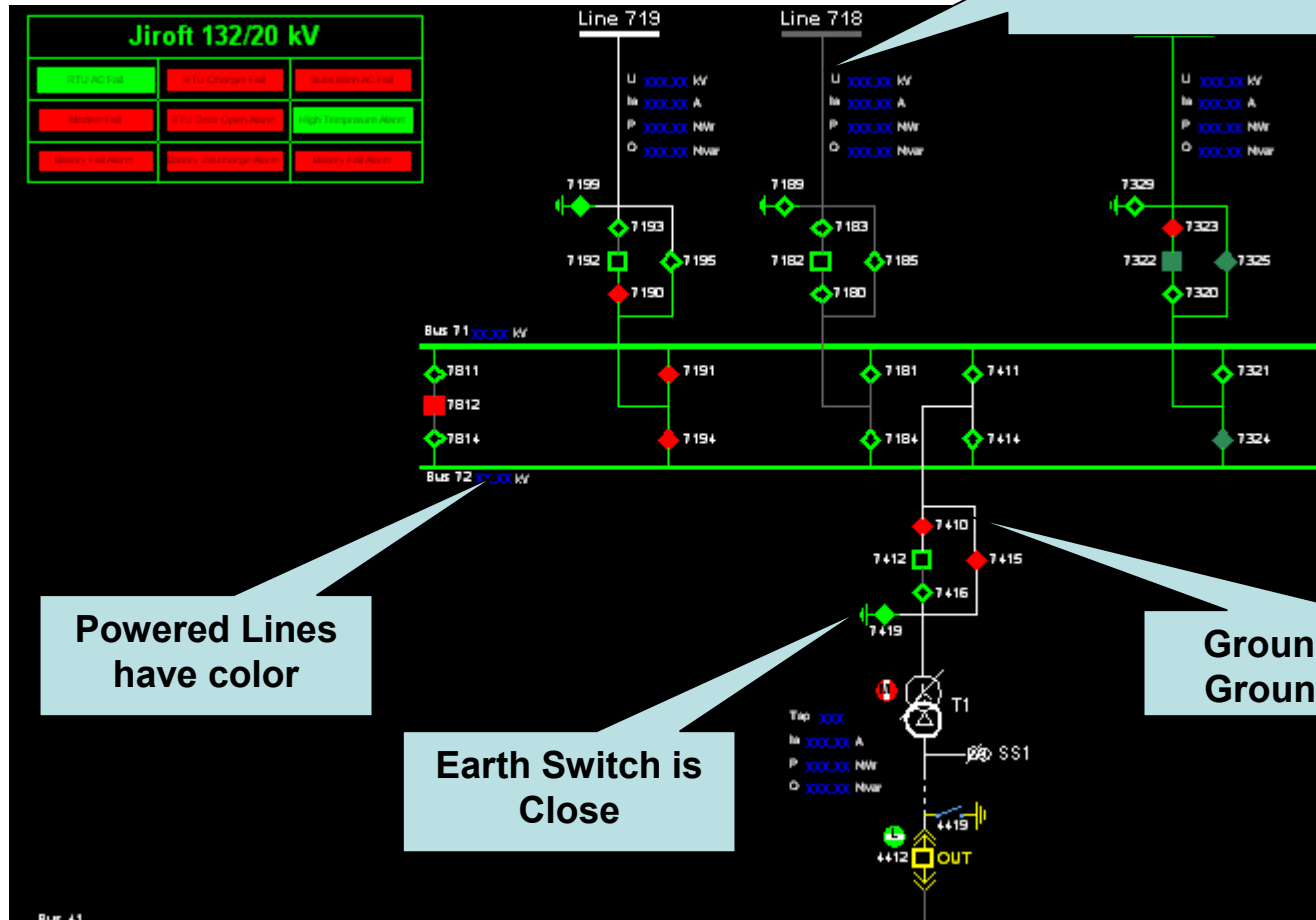

SCADA Features

V-SCADA2000 Front End System

Front End system

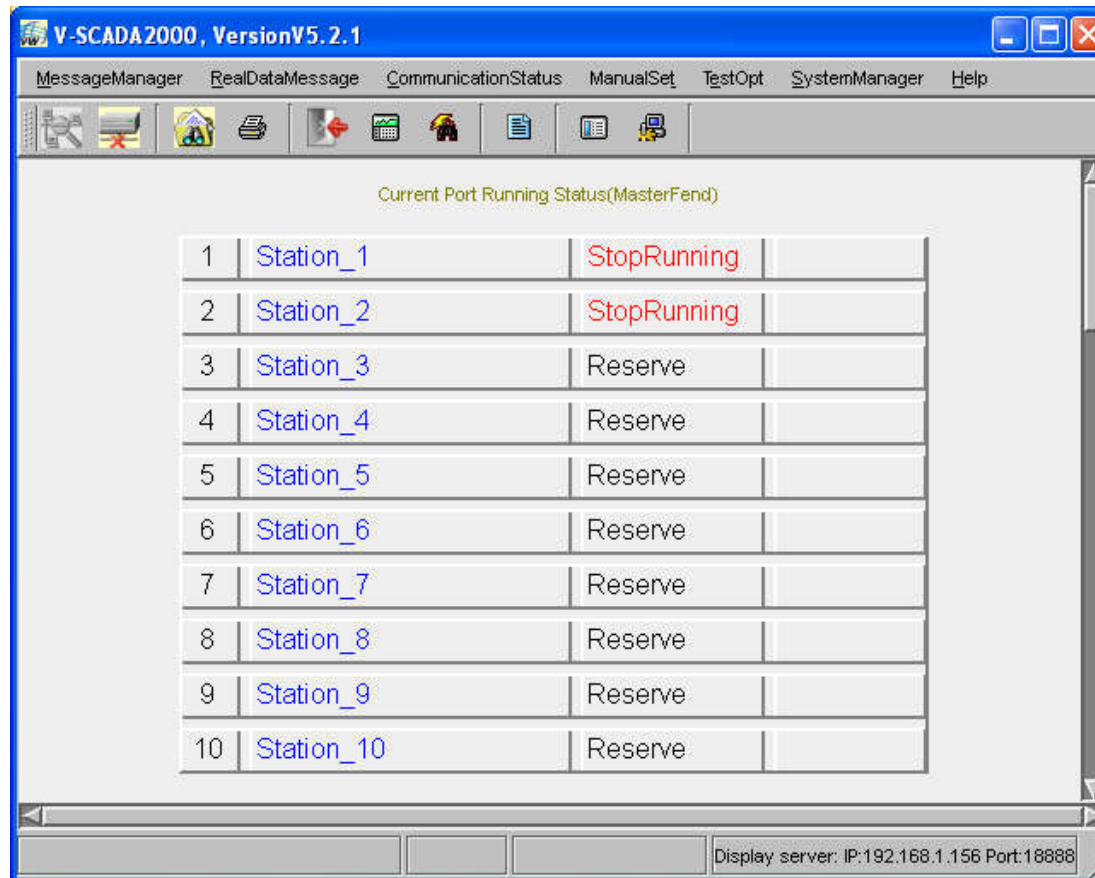

The screenshot displays the V-SCADA2000 software interface. The title bar reads "V-SCADA2000, VersionV5.2.1". The menu bar includes "MessageManager", "RealDataMessage", "CommunicationStatus", "ManualSet", "TestOpt", "SystemManager", and "Help". The toolbar contains various icons for system management. The main display area is titled "Current Port Running Status(MasterFend)" and contains a table with 10 rows of station data.

Station ID	Station Name	Status	Additional Info
1	Station_1	StopRunning	
2	Station_2	StopRunning	
3	Station_3	Reserve	
4	Station_4	Reserve	
5	Station_5	Reserve	
6	Station_6	Reserve	
7	Station_7	Reserve	
8	Station_8	Reserve	
9	Station_9	Reserve	
10	Station_10	Reserve	

At the bottom right of the window, the text "Display server: IP:192.168.1.156 Port:18888" is visible.

SCADA Features

V-SCADA2000 Front End System

Port Configuration

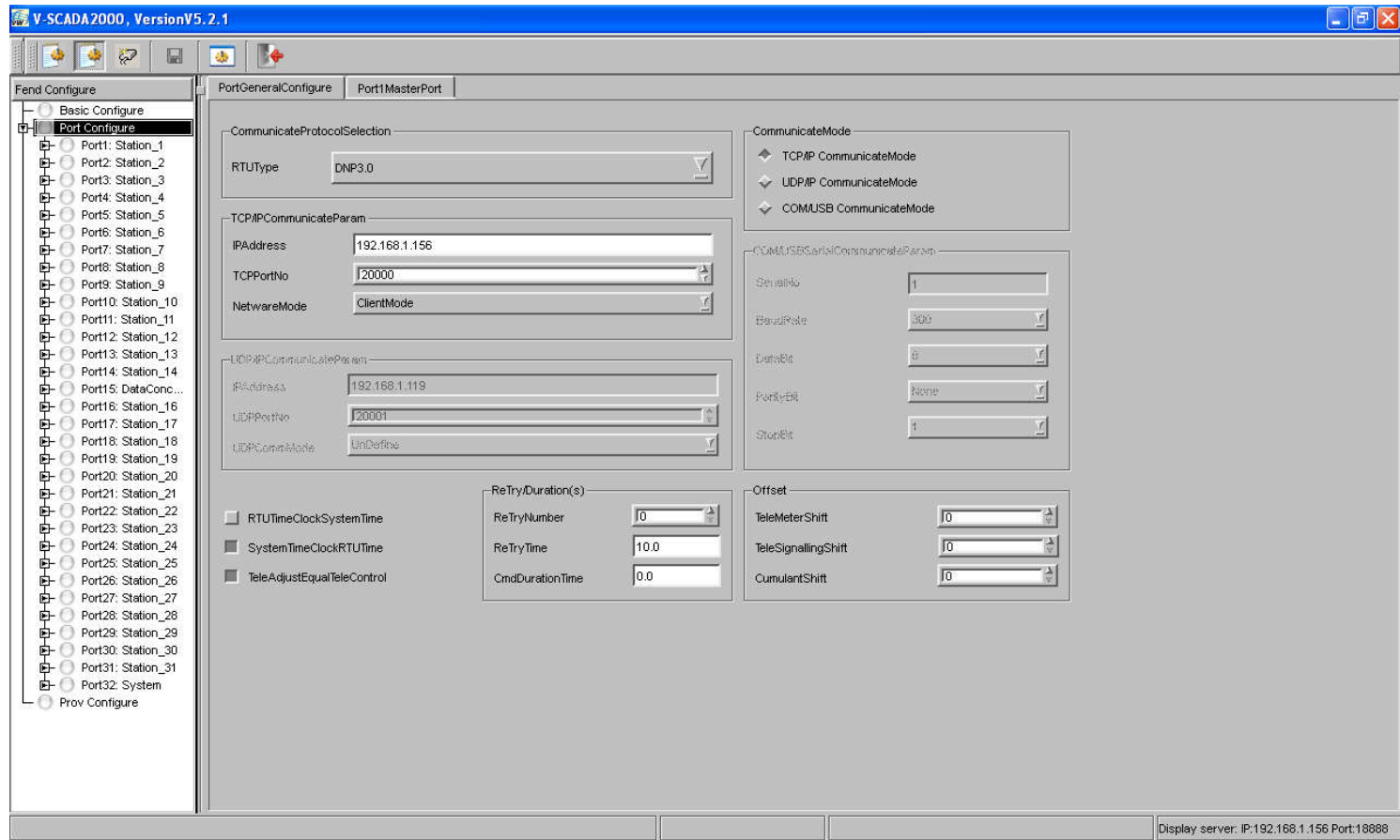

SCADA Features

V-SCADA2000 Front End System

Protocol Configuration

V-SCADA 2000, Version V5.2.1

PortGeneralConfigure Port2MasterPort

IEC60870-5-104 Communication Protocol

ConfigureSelect

CommonAddress	0
BuildingLinkOverTime0(s)	30
SendingOrTestingAPDUOverTime1(s)	15
NoDataPacketOverTime2(s)	10
LongTimeSparingSendTestOverTime3(s)	20
APDU_Max: Number	12
APDU_UnConfirmedNumber	8
TeleControlModeDefineFileName	104_siemens.dat
TeleControlMode(UnDefFileNameValid)	DoublePointTeleControl
<input type="checkbox"/> SOEStatusEqualTeleSignallingStatus	

PolingCommandPeriod(Unit:s)

GroupCallTeleSignallingData	0
GroupCallTeleMeterData	0
GroupCallCumulantData	0
AllCallCumulantData	300
CallInitializingData	300
CallJiHuaData	0
DownJiHuaData	0

VaryInformationSection

CommonAddressWidth	2
TransmitCauseWidth	2
InformationObjAddrWidth	3
TeleMeterInforStartAddr	16385
TeleSignalInforStartAddr	1
TeleCumulantInforStartAddr	25601
TeleControlInforStartAddr	24577
TeleSetInforStartAddr	25089
StepInforStartAddr	26113
TeleMeterNumber	256
FrameSequenceReplySize	2
ProtocolIssueTime	2000
TeleSetCommandTypeID	48[NormalizeValue]
ProvTeleMeterTypeID	9[NormalizeWithQualityValue]
ProvTeleSignallingTypeID	1_2[SinglePointInformation]
ProvWaitInitializingTime	20
GroupTeleMeterNumber	48
OneGroupTeleSignallingNumber	127
OneGroupCumulantNumber	30

Display server: IP:192.168.1.156 Port:18888

SCADA Features

V-SCADA2000 Real-time Database Editor

Point No	Point Name	Disable Poi	The pola	Project-Val	Status	Point Enc	Factor	Original-va	Original-val	Project-Val D	Offset
1	L719 Voltage	<input type="checkbox"/>	Double	164.20	Invalid Data	<input checked="" type="checkbox"/>	0.10000000	0x0669	0	0.00	0.00
2	L719 Amper	<input type="checkbox"/>	Double	166.60	Invalid Data	<input checked="" type="checkbox"/>	0.10000000	0x0682	0	0.00	0.00
3	L719 P	<input type="checkbox"/>	Double	16.58	Invalid Data	<input checked="" type="checkbox"/>	0.01000000	0x067a	0	0.00	0.00
4	L719 Q	<input type="checkbox"/>	Double	16.64	Invalid Data	<input checked="" type="checkbox"/>	0.01000000	0x067f	0	0.00	0.00
5	L718 Voltage	<input type="checkbox"/>	Double	167.50	Invalid Data	<input checked="" type="checkbox"/>	0.10000000	0x068a	0	0.00	0.00
6	L718 Amper	<input type="checkbox"/>	Double	167.30	Invalid Data	<input checked="" type="checkbox"/>	0.10000000	0x0689	0	0.00	0.00
7	L718 P	<input type="checkbox"/>	Double	16.71	Invalid Data	<input checked="" type="checkbox"/>	0.01000000	0x0686	0	0.00	0.00
8	L718 Q	<input type="checkbox"/>	Double	16.90	Invalid Data	<input checked="" type="checkbox"/>	0.01000000	0x068f	0	0.00	0.00
9	L732 Voltage	<input type="checkbox"/>	Double	166.10	Invalid Data	<input checked="" type="checkbox"/>	0.10000000	0x067d	0	0.00	0.00
10	L732 Amper	<input type="checkbox"/>	Double	167.30	Invalid Data	<input checked="" type="checkbox"/>	0.10000000	0x0689	0	0.00	0.00
11	L732 P	<input type="checkbox"/>	Double	16.61	Invalid Data	<input checked="" type="checkbox"/>	0.01000000	0x067c	0	0.00	0.00
12	L732 Q	<input type="checkbox"/>	Double	16.67	Invalid Data	<input checked="" type="checkbox"/>	0.01000000	0x0683	0	0.00	0.00
13	L722 Voltage	<input type="checkbox"/>	Double	167.10	Invalid Data	<input checked="" type="checkbox"/>	0.10000000	0x0687	0	0.00	0.00
14	L722 Amper	<input type="checkbox"/>	Double	170.00	Invalid Data	<input checked="" type="checkbox"/>	0.10000000	0x06a3	0	0.00	0.00
15	L722 P	<input type="checkbox"/>	Double	16.76	Invalid Data	<input checked="" type="checkbox"/>	0.01000000	0x068c	0	0.00	0.00
16	L722 Q	<input type="checkbox"/>	Double	16.70	Invalid Data	<input checked="" type="checkbox"/>	0.01000000	0x0685	0	0.00	0.00
17	Bus 71 Voltage	<input type="checkbox"/>	Double	167.90	Invalid Data	<input checked="" type="checkbox"/>	0.10000000	0x068f	0	0.00	0.00
18	Bus 72 Voltage	<input type="checkbox"/>	Double	169.70	Invalid Data	<input checked="" type="checkbox"/>	0.10000000	0x06a0	0	0.00	0.00
19	T1 Tap	<input type="checkbox"/>	Double	16.53	Invalid Data	<input checked="" type="checkbox"/>	0.01000000	0x0674	0	0.00	0.00
20	T1 A	<input type="checkbox"/>	Double	165.60	Invalid Data	<input checked="" type="checkbox"/>	0.10000000	0x0678	0	0.00	0.00
21	T1 P	<input type="checkbox"/>	Double	169.30	Invalid Data	<input checked="" type="checkbox"/>	0.10000000	0x069d	0	0.00	0.00
22	T1 Q	<input type="checkbox"/>	Double	167.10	Invalid Data	<input checked="" type="checkbox"/>	0.10000000	0x0687	0	0.00	0.00
23	T2 Tap	<input type="checkbox"/>	Double	16.85	Invalid Data	<input checked="" type="checkbox"/>	0.01000000	0x0695	0	0.00	0.00
24	T2 A	<input type="checkbox"/>	Double	170.00	Invalid Data	<input checked="" type="checkbox"/>	0.10000000	0x06a3	0	0.00	0.00
25	T2 P	<input type="checkbox"/>	Double	169.40	Invalid Data	<input checked="" type="checkbox"/>	0.10000000	0x069e	0	0.00	0.00
26	T2 Q	<input type="checkbox"/>	Double	169.00	Invalid Data	<input checked="" type="checkbox"/>	0.10000000	0x0699	0	0.00	0.00

SCADA Features

V-SCADA2000 Provides ...

- Status Data
 - Two-State Device Control such as circuit breakers, isolators, etc.
 - Single-State such as alarms
 - Six state devices, such as auto reclose relays
 - BCD Tap position
- Analogue Data
 - Megawatts, Mvars, kV, water level, flow rate
- Accumulator Data
 - Power station sent out Megawatts and Mvars
- Supervisory control
 - Device Control such as, breaker control, Auto manual.
 - Setpoint Device Control, Auto Reclose Relay setting
 - Pulse control such as AGC up or down, tap change control
 - Static Var Compensator voltage or Mvar set point

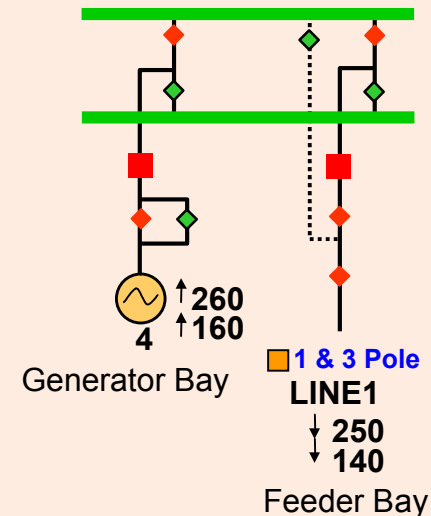

SCADA Features

V-SCADA2000 Status Data ...

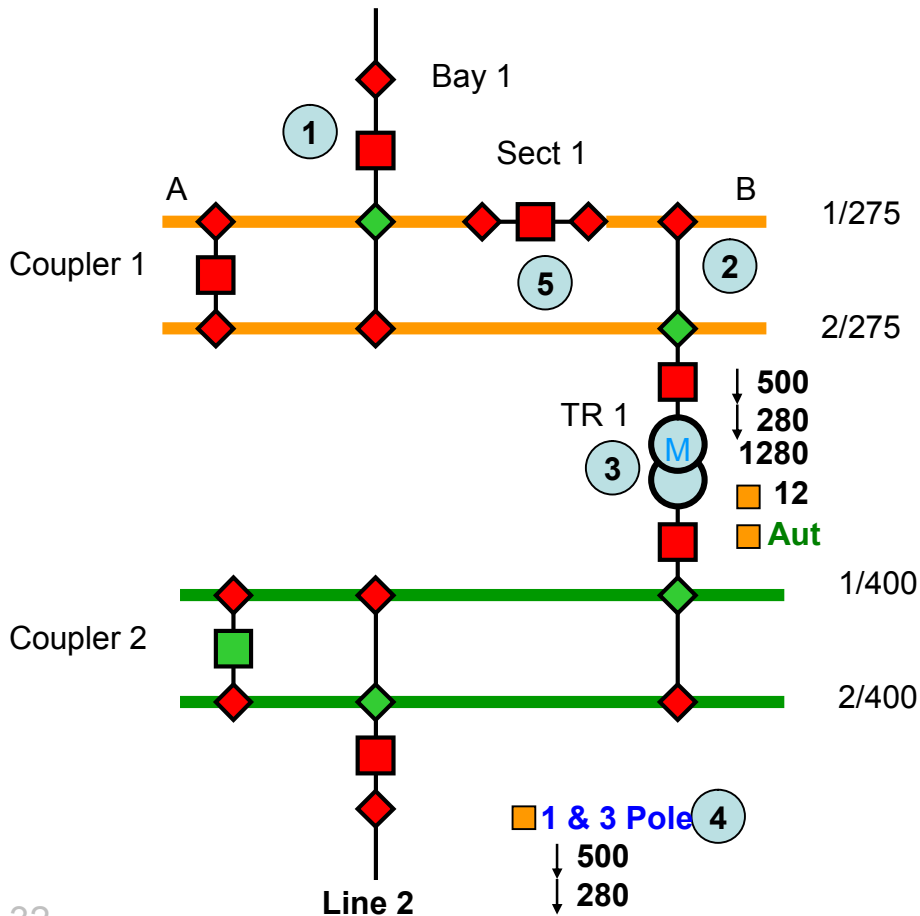

Status Data

- Two-State or double bit Device such as circuit breakers, isolators, etc.
- Single-State such as alarms and indications
- Six state devices, such as auto reclose relays.
- BCD Tap position indication

SCADA Features

V-SCADA2000 Analog Data ...

Substation Analog values

- Megawatt
- Mvar
- Amps
- Voltage
- Frequency
- Transformer oil temperature (actual values)
- Transformer Tap position
- Conductor Temperature (New)
- Dam Water Level

Derived analog value alarms

- Area Loads
- Tap changer rate of change

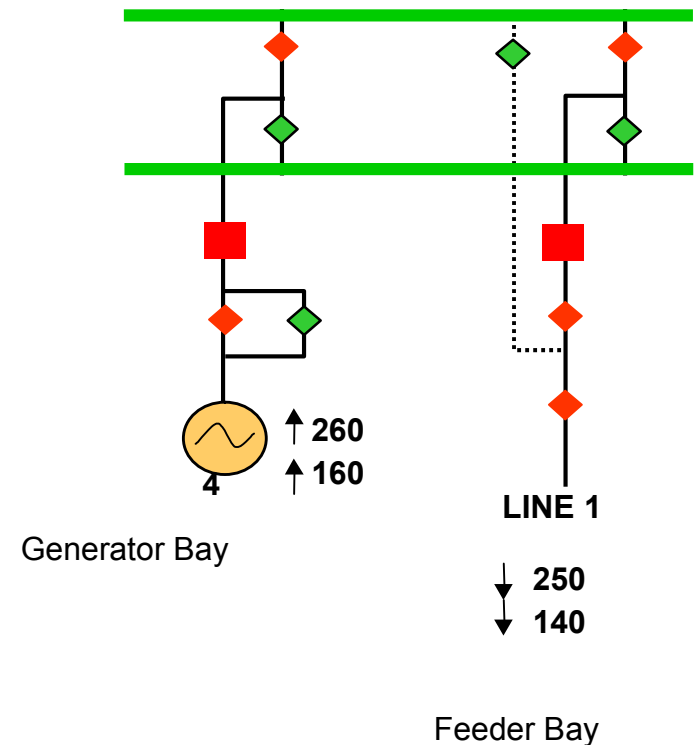

SCADA Features

V-SCADA2000 Analog Data Conversion ...

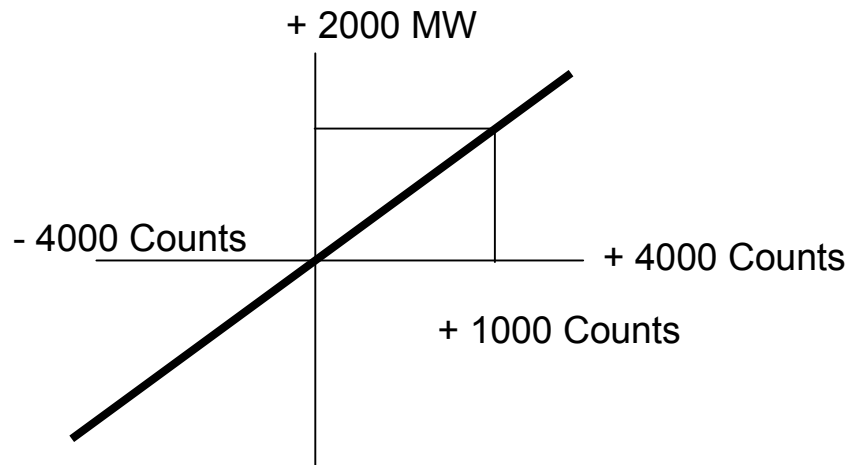
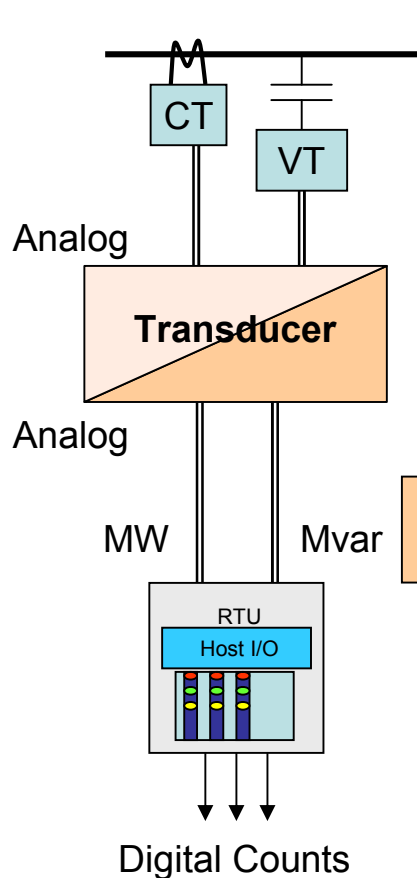

If the counts from the RTU is 1000 what is the engineering value?

$$y = mx + c \quad \text{where} \quad m = \frac{2000}{4000} \quad ; \quad c = 0$$

$$Y = \frac{2000}{4000} \times 1000 + 0$$
$$= 500 \text{ MWs}$$

V-SCADA2000 Product Series

Hardware Platform	Support	Operating System Platform	Support	Note
Intel x86	✓	Windows Family NT/2K/2003	✓	Support various Mixed platform from Operating System and Hardware platform
Intel x86	✓	Unix Sun Solaris 10 for x86	✓	
Intel x86	✓	Linux OS Family, RedHat, Suse, etc	✓	
AMD	✓	Windows Family, Linux Family	✓	
Sun Sparc	✓	Unix Sun Solaris 8, 9, 10	✓	
IBM Power System	✓	IBM Unix Aix 5L	✓	
Alpha	✓	Tru64 Unix	✓	
HP Minicomputer	✓	HP-Unix, VMS	✓	

V-SCADA2000 Product Series

Item	Capacity	Item	Capacity
Analog Input Points	150,000	Calculation Points	60,000
Digital Input Points	500,000	Event recall	150,000
Pulse Counter Points	30,000	Sequence Of Event	No limit
Digital Output Points	60,000	Picture & Screen	No limit
Analog Output Points	30,000	History Curve	No limit
System interface to RTU	256 (expandable)	Number of Workstations	Up to 26
Communication baud rate	From 300bps up to 10/100/1000Mbps		
Communication interface	Can be interconnected with various devices		
Channel rate of remote computer	64Kbps - 2Mbps		

**Above Capacity of points are expected on the single quad core computer system.
We can have more & more capacity if we use from distributed computer structure.**

V-SCADA2000 Product Series

V-SCADA2000 Technical Characteristics

- Multi operating system platform
- Open-Type layered
- Object Oriented Technology
- Cross Platform hardware feature
- Powerful embedded Scripting language
- Providing as a second development system
- Distributed architecture
- Advance data transmission technology
- Reliable data processing system
- Universal interfaces
- Advanced Man-Machine Interface
- Safe Powerful World Wide Web Distribution
- System function parallelization
- Several Data source and Protocol type

Veesta World Co. has absorbed the latest domestic and foreign research results and drawn on the 10-years practical experience on automation monitoring system. The successful development of system of V-SCADA2000 push us on the leading position both in product technology and after-sales services. Our products can hold the competitiveness even in comparison with the other similar products. V-SCADA2000, in the power industry integrated with Power Application Systems (PAS) as well as Distribution Management System (DMS) and integrated with V-BPM.



Thank You

No 21. Parastoo Alley, Arasbaran St.
NW-SeyyedKhandan Bridge
Tehran – IRAN

Tel: +98-21-22883595

Fax: +98-21-22883594

Email: info@veesta-world.com

Web: <http://www.veesta-world.com/> , <http://www.veesta.com/>

