

V-COM2000 Series



VC-2DCU

Data Concentrator Unit & GPS Time
Veesta Communication System 2000 Product Series



Author: Veesta World Co., Engineering Department

TRADEMARKS

VEESTA and **VEESTA WORLD** are trademarks of Veesta World Co. Iran

V-COM2000 is trademarks of Communication product of VEESTA WORLD Co.

NOTICE

The information in this document is subject to change without notice and should not be construed as a commitment by VEESTA WORLD Co. Veesta World Co assumes no responsibility for any errors that may appear in this document.

In no event shall Veesta World Co be liable for direct, indirect, special, incidental or consequential damages of any nature or kind arising from the use of this document, nor shall Veesta World Co be liable for incidental or consequential damages arising from use of any software or hardware described in this document.

This document and parts thereof must not be reproduced or copied without Veesta World Co's written permission and the contents thereof must not be imparted to a third party nor be used for any unauthorized purpose.

TABLE OF CONTENT

Chapter 1 - Introduction	8
1.1 General Information.....	8
1.2 Veesta World Co	8
1.3 Copyrights	9
Chapter 2 - System Overview	10
2.1 Overview	10
2.2 Summary of Functions.....	10
2.2.1 RTU reads	11
2.2.2 CC commands	12
2.2.3 Synchronize time	12
2.2.4 Communication and system information	12
2.3 Summary of Data Functions.....	13
2.3.1 Data Acquisition Processing	13
2.3.2 Control Output.....	13
2.4 Hardware Structure	14
2.4.1 Power Supply Unit	14
2.4.2 Main Unit.....	14
2.4.3 Interface Modules	15
2.4.4 GPS Time Module, VC-2DCUGT1 Card	15
2.5 VC-2DCU Series Hardware and Software Training.....	16
2.5.1 Curriculum Schedule Syllabus	16
2.6 Standards.....	17
Chapter 3 - Design Structure	18
3.1 Overview	18
3.1.1 VC-2DCUMU1 Introduction.....	18
3.1.2 VC-2DCUMU2 Introduction.....	19
3.2 Hardware Block Diagram.....	20
3.3 Main Unit Design	21
3.3.1 VC-2DCUMU1 Design	21
3.3.2 VC-2DCUMU2 Design	22
Chapter 4 - Main Unit Specifications	23
4.1 General.....	23
4.2 Central Processing Unit.....	23
4.3 Software Configuration	23

4.4	VC-2DCUMU1 Model	23
4.4.1	Front Panel	24
4.4.2	LCD and Keypad.....	24
4.4.3	Rear Panel.....	24
4.4.4	Interface Slots.....	24
Chapter 5 -	Interface Specifications	25
5.1	General.....	25
5.2	NETWORK Card	25
5.2.1	VC-2DCUNM1,2,4 Specifications	25
5.2.2	VC-2DCUNM6 Specifications	26
5.3	SERIAL Card.....	27
5.3.1	VC-2DCU06S Specifications.....	27
5.3.2	VC-2DCU12S Specifications.....	28
5.3.3	VC-2DCU16A Specifications.....	29
5.4	Modem Card.....	30
5.4.1	VR-2424 Data Modem Specifications	30
5.4.2	VR-2444 Voice & Data Modem Specifications	31
Chapter 6 -	Time Module Specifications	32
6.1	General.....	32
6.2	Specification	33
6.2.1	Time Module General Characteristics.....	33
6.2.2	Time Interface Specifications.....	33
6.2.3	Antenna Specifications	34
Chapter 7 -	Communication Protocols	36
7.1	General.....	36
7.2	DNP3.0 Profile.....	36
7.3	IEC60870-5-101 / 104 Interoperability.....	42
7.3.1	Network Configuration	42
7.3.2	Link Layer	42
7.3.3	Application Layer	43
7.3.4	Basic Application Functions	45
7.4	MODBUS Protocol	48
7.4.1	Communication and devices	48
7.4.2	Frame Format	48
7.4.3	Supported Function Codes	48
7.4.4	Implementations.....	49
7.5	Hitachi HC4300 Protocol	50
7.6	INDACTIC 2033 Protocol	51
7.6.1	Network Configuration	51
7.6.2	Telecommunications.....	51
7.6.3	Commands	51
7.6.4	Setpoints.....	52
7.6.5	Change of State Indications.....	52

	7.6.6	Counters	52
	7.6.7	Measurands	52
	7.7	ABB SPA-Bus Protocol.....	53
	7.8	Other Protocols	53
Chapter 8 -		Installation & Connections	54
	8.1	Overview	54
	8.2	VC-2DCUMU1 Model	55
	8.2.1	Power Supply Source	55
	8.2.2	Ethernet Ports.....	55
	8.2.3	Mode of Simple RS232 Ports.....	56
	8.2.4	Mode of RS-232 + Flow Control.....	56
	8.2.5	Mode of RS-232 + Clock Signal.....	57
	8.2.6	Mode of RS-232 + Clock Signal + Flow Control.....	57
	8.2.7	Mode of RS-485.....	58
	8.3	VC-2DCUMU2 Model	59
	8.3.1	Power Supply Source	59
	8.3.2	Ethernet Ports.....	59
	8.3.3	Mode of Simple RS232.....	60
	8.3.4	Mode of RS-232 + Flow Control.....	60
	8.3.5	Mode of RS-485.....	61

TABLE OF FIGURES

Figure 1-1: Veesta World Co Logo and sign.....	9
Figure 2-1: VC-2DCU Sequence Diagram.....	11
Figure 3-1: VC-2DCUMU1 Physycal Strcutre.....	18
Figure 3-2: VC-2DCUMU2 Physycal Strcutre.....	19
Figure 3-3: VC-2DCU Hardware Block Diagram	20
Figure 3-4: VC-2DCU Any-to-Any Protocols.....	21
Figure 3-5: VC-2DCUMU1 Main Unit Diagram	21
Figure 3-6: VC-2DCUMU2 Main Unit Diagram	22
Figure 4-1: VC-2DCUMU1 Front Panel.....	24
Figure 4-2: VC-2DCUMU1 Rear Panel.....	24
Figure 6-1: VC-2DCU Time System (VC-2DCUGT1 Module) View in action	32
Figure 8-1: VC-2DCUMU1, Power Source, Connection Wiring	55
Figure 8-2: VC-2DCUMU1, Ethernet Port, Connection Wiring	55
Figure 8-3: VC-2DCUMU1, Serial Port, RS232 Simple Connection Wiring	56
Figure 8-4: VC-2DCUMU1, Serial Port, RS232+Flow Control Connection Wiring.....	56
Figure 8-5: VC-2DCUMU1, Serial Port, RS232+Clock Signals Connection Wiring ...	57
Figure 8-6: VC-2DCUMU1, Serial Port, RS232+Clock+Flow Control Wiring	57
Figure 8-7: VC-2DCUMU1, Serial Port, RS485 Connection Wiring	58
Figure 8-8: VC-2DCUMU2, Power Source, Connection Wiring	59
Figure 8-9: VC-2DCUMU2, Ethernet Port, Connection Wiring	59
Figure 8-10: VC-2DCUMU2, Serial Port, RS232 Simple Connection Wiring	60
Figure 8-11: VC-2DCUMU2, Serial Port, RS232+Flow Control Connection Wiring...	60
Figure 8-12: VC-2DCUMU2, Serial Port, RS485 Connection Wiring.....	61

INDEX OF TABELS

Table 2-1: VC-2DCU Training Syllabus.....	16
Table 7-1: VC-2DCU, DNP3.0 Device Profile Document.....	36
Table 7-2: VC-2DCU, DNP3.0 Interoperability Table	38

Chapter 1 - Introduction

1.1 General Information

This is user's manual of VC-2DCU product from V-COM2000 Product Series, the Data Concentrator Unit and GPS Clock source with various interface ports from Veesta World Company. This document helps you to find about how VC-2DCU works and designed for your purpose.

This is technical information of design of VC-2DCU, the Veesta-Data Concentrator Unit, a product from V-COM2000 Series from Veesta World Company. This document helps you to find about how VC-2DCU works and designed for your purpose.

VC-2DCU of V-COM2000 system adopted for from very small data concentrator from that can be used in substation data gathering up to very large scale Data Concentrator Unit for large control centre and data conversion, protocol gateway, data router for operating centers.

1.2 Veesta World Co



Veesta World Co is a leading company in automation field in Iran and specialized in design and installation of IT Network of wide area and local area, Automation control units, control rooms, DCS design, PLC and SCADA application installation and system integration. The main advantage of Veesta World's products is complying international standards and do customs basic design.

Veesta World Co is a dynamic company located in the Tehran, IRAN, whose main commitment is the customer's satisfaction. Business vision and its future evolution together with the proper combination of new and existing technologies are the main aspects considered in the solutions proposed by Veesta World Co. Owing to this, key issues like Scalability, the Return of Investment or the Total Cost of Ownership are carefully considered. Consequently, the solutions offered by Veesta World Co are able to cope with the requirements of a sustainable growth. Veesta World Co is a service-oriented

company and the customer perspective is its action guide. An added value of the offer is the evaluation and Management of the risk. This issue is getting a major relevance in the changing environment in which new technologies have to be applied, particularly when profitability is a major concern.

The objective of Veesta World Co is focused on the creation of value for the customer through the proper business strategy alignment and the right combination of technologies. These principles, developed under the Total Quality Management practice, allow Veesta World Co to offer, in a seamless approach, consultancy, engineering and training services.

The founders of Veesta World Co are professionals with a large experience in the Telecommunication and Networking and Industrial fields.

Veesta World Co is formed by a balanced team of professionals that gather knowledge in a wide range of technologies and specific know-how on how to apply these technologies in mission-critical control networks.

1.3 Copyrights

All of documents and materials in related to this document and this document are copyrights of Veesta World Co and it is not permitted to use or transfer the contents to any other parties.

The Veesta World Co logo is registered trademark of Veesta World Co and its properties.



Figure 1-1: Veesta World Co Logo and sign

Chapter 2 - System Overview

2.1 Overview

The VC-2DCU, Data Concentrator Unit (DCU) product is a communication system which is used to convey protocol signal information between power utility installations over the H.V. (400kv & 230kv & 132kv) Remote Terminal Unit systems and SCADA control centers,

VC-2DCU provides not only protocol conversion in the level of signal information but also have ability to maintain, design, routing, specific information and controls to/from various substations with various electrical protocols to various control centers with difference protocols.

The VC-2DCU provides following functions:

- **VC-2DCU as network switch** forwards commands to/from a particular RTU's substation for information by various protocols.
- **VC-2DCU as network router** has some intelligence regarding the grouping and de-grouping (splitting) of substations information and various protocols.
- **VC-2DCU as smart component** has specific intelligent functionality on behalf of smart RTU substations and intelligent grids.

2.2 Summary of Functions

The functional description of the data concentrator unit is placed between the Control Center (CC) and the Remote Terminal Units (RTU) and other DCU(s). The final objective is that the DCU will be interoperable, in both interfaces. The functional requirements of the DCU depend on the use case involved and may vary from very simple to very smart.

The generic sequence diagram of a site configuration with a VC-2DCU is described in

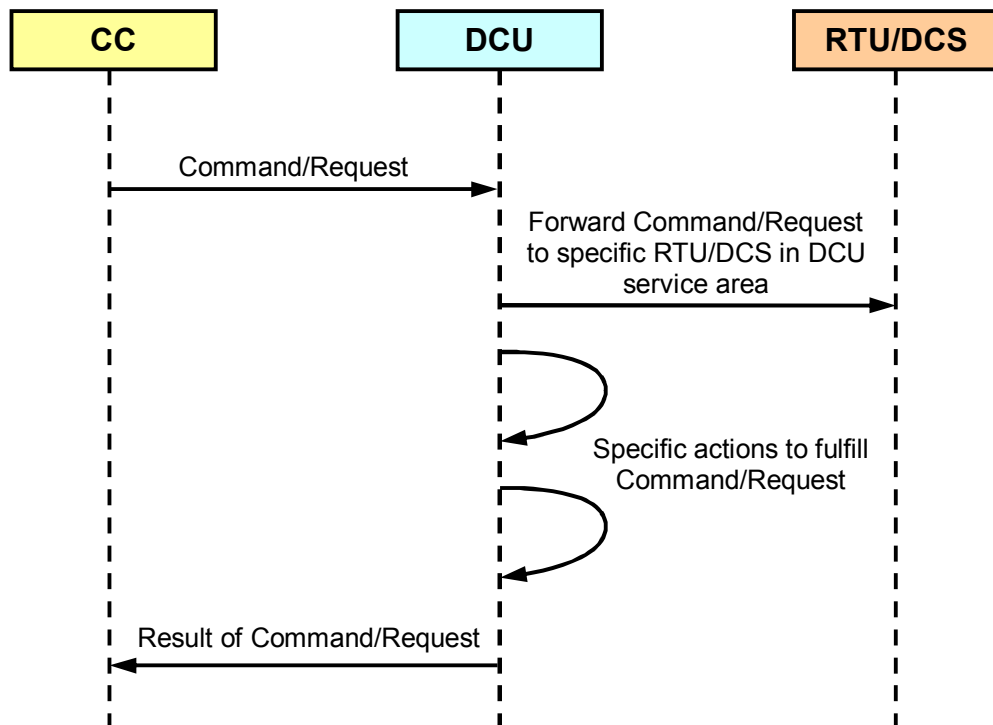

Figure 2-1: VC-2DCU Sequence Diagram

2.2.1 RTU reads

The VC-2DCU provides functionality to retrieve the pooling RTU reads for a specified period in selected communication protocol in the VC-2DCU database. The VC-2DCU is able to check if all required data is available after such a periodic RTU read.

Pooling RTU reads for RTUs or DCSs need to be available, according to protocol specification like Hitachi, IEC101, DNP3.0, etc. The VC-2DCU shall collect all RTU reads for analogue and digital information in the VC-2DCU database and then send all those information reads at once to the CC.

The VC-2DCU is able to address all RTUs in the VC-2DCU database and to retrieve for the mentioned period (to be specified as a parameter of protocols):

- Single Point Information
- Double Point Information Object
- Step Position Information Object
- Measured value Normalized/ Scaled/ Short floating/ Information Object
- Integrated Totals Information Object
- Sequence Of Event Object
- Quality Descriptors of Object
- Bit string of 32 bits Object

2.2.2 CC commands

The process of CC commands therefore has two types of triggers: one for global or broadcast commands and one for specific addressed command; however, for each type of trigger, there are several possibilities.

The VC-2DCU provides functionality to forward a command request, which was sent by the CC, for a connected or disconnected of the RTUs to the concerning information Object like system and application commands in RTU in substations.

The VC-2DCU is able to address all RTUs in the VC-2DCU database and for the remote activation / deactivation for the mentioned commands (to be specified as a parameter of protocols):

- Single Command Object
- Double Command Object
- Regulating Step Command Object
- Set point normalized/ scaled value/ short floating Command Object
- Initialization process commands
- Integration Command Object
- Counter interrogation Command
- Read Command
- Test Command
- Clock synchronization Command
- Parameters and application Command

2.2.3 Synchronize time

VC-2DCU is able to verify that the internal clock of the RTU equipment is operating and set correctly, the CC has to be able to synchronise the time of the RTU equipment. In case a VC-2DCU is used, the CC has to be able to synchronise the time of the VC-2DCU and the VC-2DCU has to be able to synchronise the time of the RTU or DCS equipment.

2.2.4 Communication and system information

The VC-2DCU provides functionality to retrieve the communication and system status of internal of VC-2DCU Information from all of RTU channels in the VC-2DCU database.

The VC-2DCU is able to address all RTUs in the VC-2DCU database and to retrieve the outage Information. After data retrieval has been carried out, all required data is available.

2.3 Summary of Data Functions

2.3.1 Data Acquisition Processing

VC-2DCU acquires digital and analog signal from remote station and stores it in DCU memory. On the other band, VC-2DCU accepts host command to reflect and transmit back the required data to control center.

2.3.1.1 Analog Data Input

Measured Values, generally to receive signals from power transducers (Watt / Var / Voltage / Current / Temperature / Position / Resistance / etc), this is meant; VC-2DCU is to gather all physical signals of main facilities in remote station.

2.3.1.2 Accumulated Data Input

Energy Counters, accumulation and processing of pulses from external energy measurement devices are supported.

2.3.1.3 Digital Data Input

Indications, Status of facilities are acquired. Two basic indication types are supported: Single indication Double indication.

- **Single indication (1-Bit Status):** involve only a single monitored external point and hence, have only two states: 0 or 1.
- **Double Indication (2-Bit Status):** involve the monitoring of two physical external points and hence, can provide four states: 0/0, 0/1, 1/0, 1/1.

2.3.1.4 Sequence of Event Report

In order to monitor the status and sequence, changed of main equipments, VC-2DCU provides the SOE function (Sequence Of Event).

2.3.2 Control Output

Two types of control command can be transmitted from the Master Station to devices in the Power System via the VC-2DCU. One is Trip/Close command, the other is Direct Set-point command.

2.3.2.1 Trip/Close Command

There are two types of control output using Trip/Close command, one is ON/OFF operation output to control CBs, ABSs; the other is Regulation operation output (raise/lower) to control the position of transformer taps. Two distinct types of Trip/Close commands are supported:

- **Execute Immediate Command:** Direct Trip/Close Command, are executed as a single command message, and transmitted to the addressed RTU.
- **Select Before Operate (SBO) Command:** Select Trip/Close Command & Operate Command, are executed as two distinct commands to the addressed RTU; a select command followed by an execute command.

2.3.2.2 Set-point Command

There are two types of control output using Direct Set-point command, one is Digital Direct Set-point, and the other is Analog Direct Set-point.

2.4 Hardware Structure

VC-2DCUMU1 hardware structure is designed as a Plug-In Type and set up in 19" Rack/Module enclosure with 1U height. The ideal plug-in type configuration provides a very useful structure in maintenance. The VC-2DCUMU2 is smaller and wall mount device with limited interface and connections

2.4.1 Power Supply Unit

The power supply of VC-2DCU contains four options the power supply type must be specified during purchase order:

- **Single Unit DC Power source** designed in DC 36V~75V input,
- **Single Unit AC Power source** designed in AC 110~280V input,
- **Dual Unit AC+AC Power source** designed in two AC source as redundant power supply source,
- **Dual Unit AC+DC Power source** designed in AC and DC power source as redundant power supply,

2.4.2 Main Unit

2.4.2.1 VC-2DCUMU1 Chassis

The main unit of VC-2DCUMU1 consists of 1 Backplane and 1 Master CPU module. It contains three slots to place some interface modules.

First slot only accept Ethernet modules and next two slots can be used for serial interface modules.

2.4.2.2 VC-2DCUMU2 Chassis

The unit of VC-2DCuMU2 consists of 1 board that contact master CPU plus communication interface. The interfaces consist of 2 Ethernet port and 4 programmable RS232/485 serial ports.

2.4.3 Interface Modules

VC-2DCU provides various types of I/O interface card which coincidentally to the requirement of station. In order to have modularity and monitor and study dynamic status of system operation and feature of facilities, interface cards are defined by functions for different system inputs as under description:

- **VC-2DCUNM1 Card:** Network Module, 1 Ethernet port.
- **VC-2DCUNM2 Card:** Network Module, 2 Ethernet ports.
- **VC-2DCUNM4 Card:** Network Module, 4 Ethernet ports.
- **VC-2DCU06S Card:** Sync-Serial Interface Module, 6 ports.
- **VC-2DCU12S Card:** Sync-Serial Interface Module, 12 ports.
- **VC-2DCU16A Card:** Async-Serial Interface Module, 16 ports.

2.4.4 GPS Time Module, VC-2DCUGT1 Card

The VC-2DCUGT1 Card is a synchronization reference clock which uses the GPS system (Global Positioning System) as time base by means of an internal GPS receptor or by means of an IRIG-B input. Several different signal types are supplied by the VC-2DCUGT1, making it possible to synchronize the most diverse types of equipment.

The VC-2DCU GPS satellite synchronized clock, is a processed equipment which is employed in the synchronization of equipment requiring a high degree of time accuracy. Through standardized or proprietary synchronism protocols and electric or optic outputs, the VC-2DCUGT1 synchronizes all equipment normally associated to power plants, transmission and distribution of electric energy.

The modularity and flexibility of VC-2DCU allows the VC-2DCUGT1 to be easily adjusted to comply with each application specific needs.

2.5 VC-2DCU Series Hardware and Software Training

The training is disported into two stages one stage is include the principle of Substation before install the system which last 1~3 days.

The other stage is in the laboratory after installation and debugging of the products which last 1~2 days for workshop.

2.5.1 Curriculum Schedule Syllabus

Training items	Times	Training contents	Personnel attended
Alternation layer part (I/O boards) collectivity introduce	Day 1	System block diagrams System configuration Function of adopted devices	Run maintenance personnel System development personnel
Function introduce of network and communication for Alternation layer part	Day 1	Function introduce of network and communication for system introduce of CPU introduce of inside network communication with attempter computer interface and communication with other IED	Run maintenance personnel System development personnel
Introduce of every I/O boards and network for Alternation layer part	Day 1	Introduce of hardware system use and maintenance of every I/O boards and terminal unit, principle and technical index of every I/O boards and terminal unit.	Run maintenance personnel System development personnel
Assembly and wiring part	Day 2	Advert problem of locale connection	Run maintenance personnel
Maintenance	Day 2	Introduce of locale/remote maintenance software for Alternation layer part through use PC.	Run maintenance personnel
The problem of notice	Day 2	Combine maintenance software, introduce of locale coefficient intercalate, and notice the problem of system running	Run maintenance personnel
Workshop	Day 3~4	In the workshop practice all of training program	Run maintenance personnel System development personnel

Table 2-1: VC-2DCU Training Syllabus

2.6 Standards

1. **Electromagnetic Compatibility (EMC)**
 - 1- IEC 61000-4-2: Electrostatic discharge 6 kV (contact), 8 kV (air)
 - 2- IEC 61000-4-3: Radiated RF immunity 10 V/m
 - 3- IEC 61000-4-4: Burst 1 kV IO, 2 kV Power port
 - 4- IEC 61000-4-5: Surge 2 kV (common mode)
 - 5- IEC 61000-4-8: Magnetic field immunity 100 A/m
 - 6- IEC 61000-4-11: Voltage dips
30 % during 0.5s
60 % during 0.5s
 - 7- IEC 60255-22-1: Burst 1 MHz
2.5 kV (common mode),
1.25 kV (differential mode)
2. **Safety Standards**
 - 8- IEC 664-1: Dielectric Test: 1 kV @ 1 min, 2 kV Impulse, Insulation Resistance > 5Mohm @ 500 V.
3. **Environment Standards**
 - 9- IEC 60068-2-1: Cold -10°C, 16 hours, 1 cycle
 - 10- IEC 60068-2-2: Dry heat +50°C, 16 hours, 1 cycle
 - 11- IEC 60068-2-14: Change of Temperature, 25°C~+50°C, 9 hours, 2 cycles
 - 12- IEC 60068-2-30: Damp heat +55°C, 95%, 12+12 hours, 1 cycle
4. **Mechanical Standards**
 - 13- IEC 60068-2-6: Vibration (sinusoidal) 0.035 mm, 0.5 g, 1 cycle on each axis
 - 14- IEC 60255-21-1: 1 g, 20 cycles on each axis
 - 15- IEC 60068-2-27: Shock 15 g, 11 ms, 3 pulses on each face
 - 16- IEC 60255-21-2:

Chapter 3 - Design Structure

3.1 Overview

In the V-COM2000 Product Series we have two type of DCU device, one as modular design and another as stand-alone design.

3.1.1 VC-2DCUMU1 Introduction

VC-2DCUMU1 hardware structure is designed as a Plug-In Type and set up in 19" Rack/Module enclosure with 1U height. The ideal plug-in type configuration provides a very useful structure in maintenance.

You can see in the Figure 3-1 the physical hardware structure design of the intelligent VC-2DCUMU1 device.

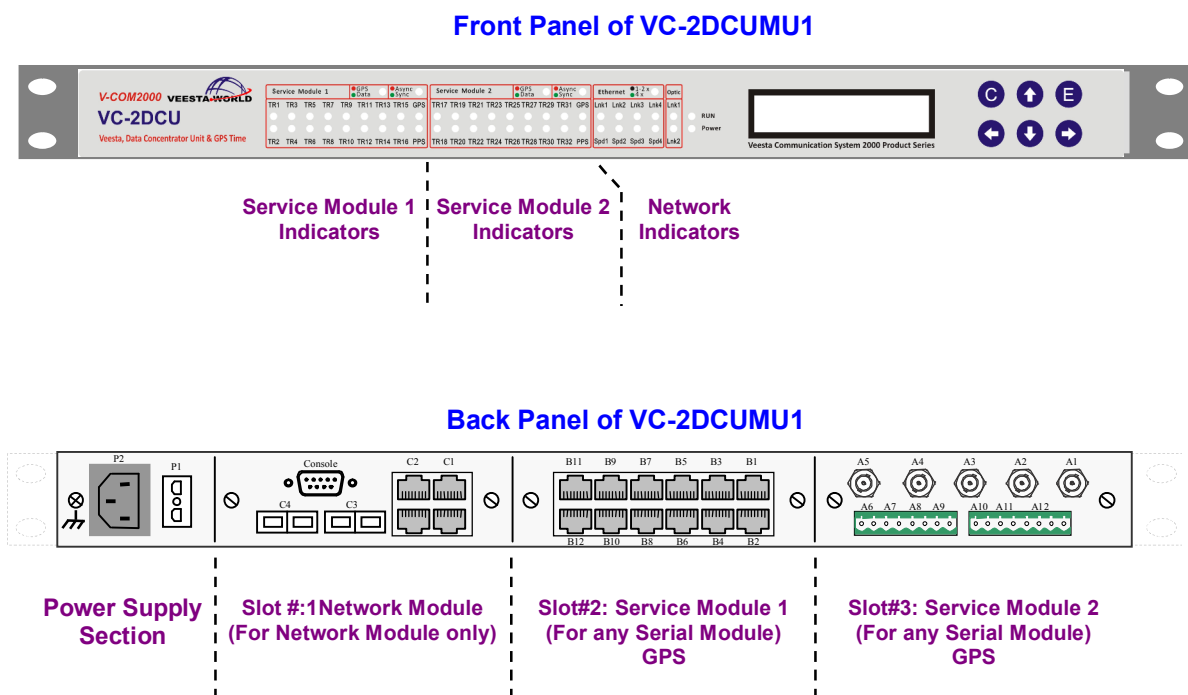

3.1.2 VC-2DCUMU2 Introduction

VC-2DCUMU2 hardware structure is designed as a stand-alone intelligent hardware box and set up in wall mount aluminum enclosure with 30mm height. The idea of this wall mount device provides a very useful structure for various projects.

You can see in the Figure 3-2 the physical hardware structure design of the intelligent VC-2DCUMU2 device.

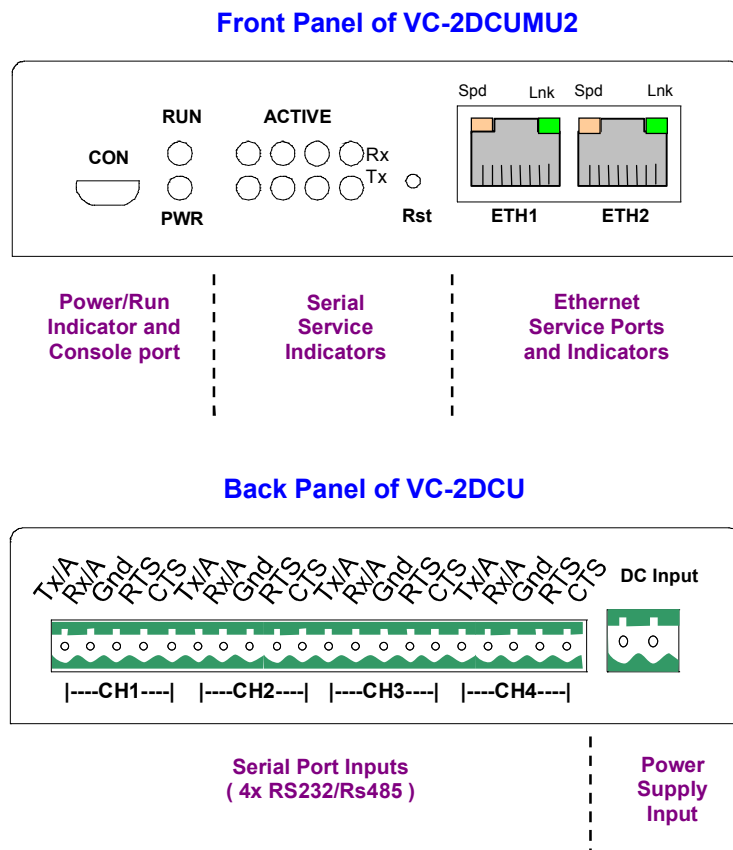

Figure 3-2: VC-2DCUMU2 Physical Structure

3.2 Hardware Block Diagram

You can see in the Figure 3-3 block diagram of internal hardware design.

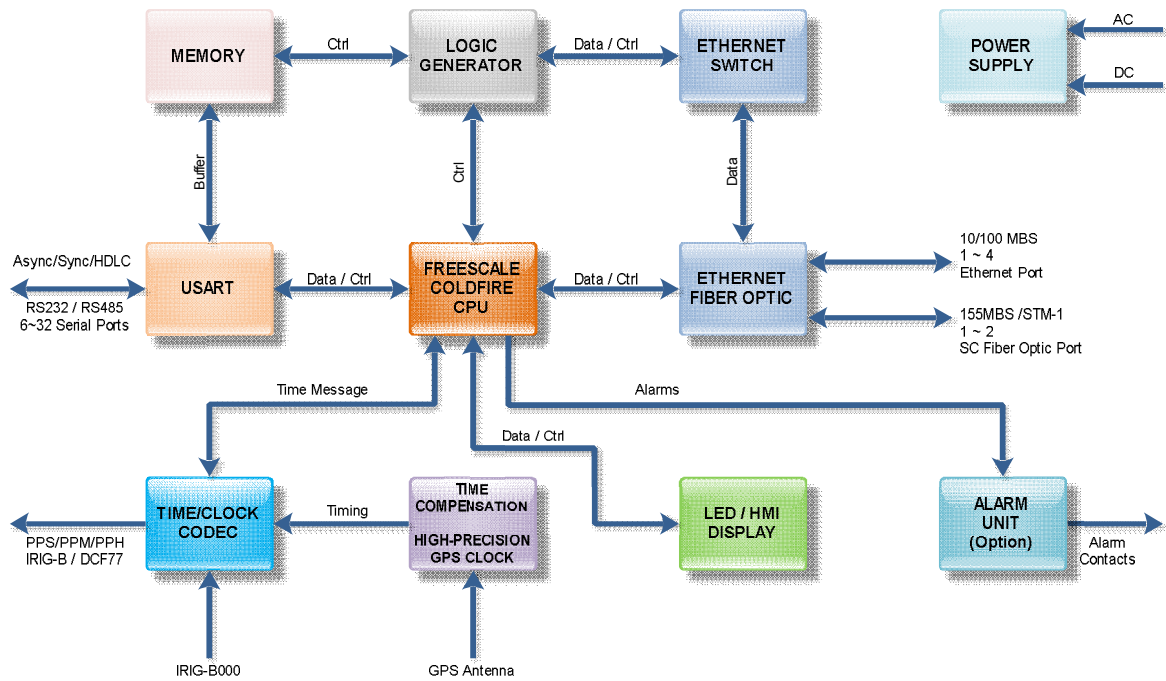

Figure 3-3: VC-2DCU Hardware Block Diagram

3.3 Main Unit Design

Based on VC-2DCU device a portion of V-RTU2000 product series we can configure that to convert any protocol. It is intelligent device of protocol converter in form of any-to-any. VC-2DCU can support any serial device protocol as well as Ethernet device protocols and vice versa.

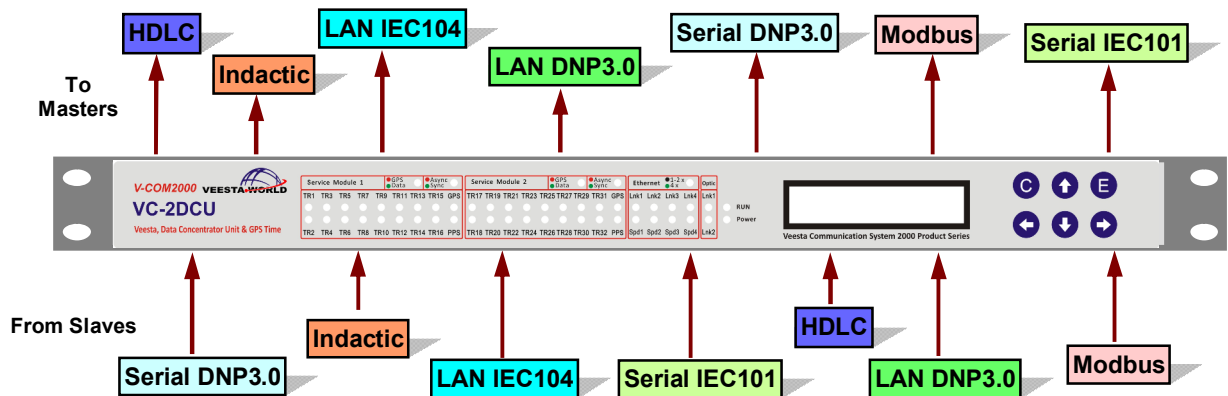

Figure 3-4: VC-2DCU Any-to-Any Protocols

3.3.1 VC-2DCUMU1 Design

The main unit of VC-2DCUMU1 consists of 1 Backplane and 1 Master CPU module. It contains three slots to place some interface modules. First slot only accept Ethernet modules and next two slots can be used for serial interface modules.

In the Figure 3-5 you can see the main unit design the relation between CPU and network and service modules.

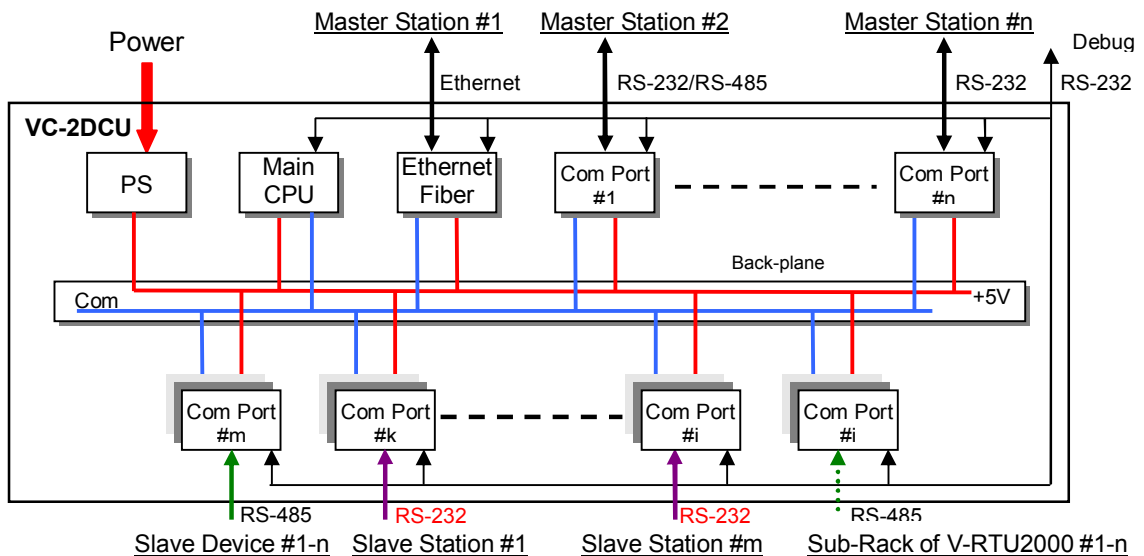

Figure 3-5: VC-2DCUMU1 Main Unit Diagram

3.3.2 VC-2DCUMU2 Design

The unit of VC-2DCUMU2 consists of one complete system and Master CPU. It contains 2 Ethernet ports and 4 programmable serial ports.

In the Figure 3-6 you can see the main unit design the relation between CPU and network and service modules.



Figure 3-6: VC-2DCUMU2 Main Unit Diagram

Chapter 4 - Main Unit Specifications

4.1 General

In this chapter we describe about each main unit of VC-2DCU that based on purpose of usage you can select desired system configuration.

4.2 Central Processing Unit

Central processing unit of VC-2DCU consists of ARM based processor. The processor speed is 100MHz in 32 bit address.

Operating system of main unit is a real time UNIX machine as micro-C Linux operating.

Total RAM depend on overall point license in two types of 16 or 32MB. System has a boot loader in a CPU by default and 32MB EEPROM as Flash memory.

4.3 Software Configuration

VC-2DCU has a high technology CIM model, software configuration that manipulates the database of VC-2DCU.

By VC-2DCU software user can define, map, localize, convert, and set transmission and a lot of concentration function in a very user friendly and real error checking software.

Software configuration has a good facility to view and monitor real time data in each interface link and also able to log and show each communication data exchange.

For more information of software part please see document of "VC-2DCU Integrated Development Environment User's Manual".

4.4 VC-2DCUMU1 Model

The VC-2DCUMU1 structure is a 19 inch rack mount device with a back panel wiring method. All of wiring of communication and power cords will be done via rear of VC-2DCUMU1 as well as replace and insertion of optional modules. By this design we have a good panel installation. We must to add in the front panel of VC-2DCUMU1 we have a display screen with LEDs indicator and LCD screen and also a 6 keys keypad.

4.4.1 Front Panel

As you can see in the figure bellow, the screen of front panel of VC-2DCUMU1 you can find some LEDs that describes about fast status of communication services. With RUN and POWER LED you can find operational status of device and based on each physical interface from LAN up to serial data we have a specific LEDs indicator.

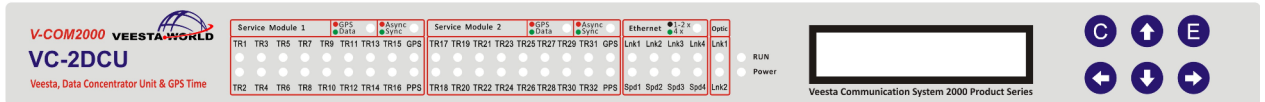

Figure 4-1: VC-2DCUMU1 Front Panel

4.4.2 LCD and Keypad

The LCD and Keypad of VC-2DCUMU1 in the front display the status and also let to configuration of high important items of device like Ethernet address and serial data mode and etc.

The very user friendly Keypad let to operator to navigate the overall status of communication unit as well as change items. For editing in the Setup menu need to have a Password.

4.4.3 Rear Panel

In the rear panel of VC-2DCUMU1, you can find power source connector or socket. Based on version of power supply in AC or DC or AC+DC case, the connector of that is a proper type.

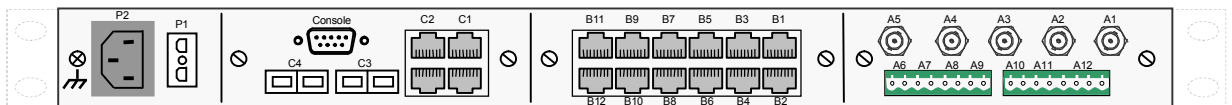

Figure 4-2: VC-2DCUMU1 Rear Panel

4.4.4 Interface Slots

In the rear panel you can find three slots for plugging communication interfaces. There are various communication interfaces that can be used in each slot.

It is reserved for the first slot of VC-2DCUMU1 a plugging card of Network module, or LAN cards. And next two slots can be universally used for various type of serial data communication.

Based on Interface used it consist of RJ45 connector to have fast wiring of communication links.

Chapter 5 - Interface Specifications

5.1 General

In this chapter we describe about each interface module of VC-2DCU that based on purpose of usage you can select desired system configuration.

In a total view, there is two type of module, one is Ethernet interface and another is serial interfaces. In the view of system capacity the VC-2DCU can support up to 4 physical Ethernet ports and up to 32 physical serial interfaces. Each module has specific feature that normally can be used in specific application.

5.2 NETWORK Card

The term of NETWORK card is related to the Ethernet or Fiber Optic device connection of VC-2DCU. There are some modular cards that we call them network modules.

5.2.1 VC-2DCUNM1,2,4 Specifications

- Type of Module** : Plug-in module in Slot1 of main unit
- Ethernet Port** : **Model VC-2DCUNM1**: 1 RJ45 Base-T Ethernet port
Model VC-2DCUNM2: 2 RJ45 Base-T Ethernet port
Model VC-2DCUNM4: 4 RJ45 Base-T Ethernet port
- Ethernet Speed** : 10/100M auto negotiate
- LAN Protocols** : SNMP, TCP/IP, Telnet protocol
- Application Protocols** : Based on license available for all application protocols like IEC60870-5-104, DNP3.0 over TCP, ModBus TCP and etc.

5.2.2 VC-2DCUNM6 Specifications

- 1. Type of Module** : Plug-in module in Slot1 of main unit
- 2. Fiber Optic Port** : 2 Ports SC duplex connector
- 3. Fiber Optic Compliant** : Compliant with 155 Mbps ATM and SONET OC-3 SDH STM-1 (S1.1)
- 4. Fiber Optic Laser** : Class 1 laser product complies with EN 60825-1
- 5. Fiber Optic Specifications** : 1310 nm, Single Mode Transceiver (S1.1, 19dB margin)
- 6. Fiber Optic Sensitivity** : -34 dBm
- 7. Fiber Optic Output Power** : -8 dBm
- 8. Ethernet Port** : 4x RJ45 Base-T Ethernet port
- 9. Ethernet Speed** : 10/100M auto negotiate
- 10. LAN Protocols** : SNMP, TCP/IP, Telnet protocol
- 11. Application Protocols** : Based on license available for all application protocols like IEC60870-5-104, DNP3.0 over TCP, ModBus TCP and etc.

5.3 SERIAL Card

The term of SERIAL card is related to the Serial device connection of VC-2DCU. There are some modular cards that we call them serial card service modules. Serial interface service modules are in three types:

- **VC-2DCU06S Card:** Sync-Serial Interface Module, 6 ports.
- **VC-2DCU12S Card:** Sync-Serial Interface Module, 12 ports.
- **VC-2DCU16A Card:** Async-Serial Interface Module, 16 ports.

5.3.1 VC-2DCU06S Specifications

1. **Type of Module** : Plug-in module in Slot2 or Slot3 of main unit
2. **Number of Serial Ports** : 6 serial ports
3. **Serial Port Standards** : Software configurable, RS232 or RS485 for each port per module
4. **Serial Port Speed** : Software configurable per port
300/600/1200/2400/4800/9600/19200/38400/57600 bps
5. **Serial Protocols Mode** : Software configurable per port Asynchronous, Synchronous, SDLC, BiSync mode.
6. **Signal Configurations** : In Async RS232:
TXD/RXD/GND/RTS/CTS signals ready
In Async RS485:
TX/RX/GND signals ready
In Sync RS232:
TXD/RXD/GND/RTS/CTS/TXC/RXC signals ready
In Bisync RS232:
TXD/RXD/GNS/RTS/CTS signals ready
7. **Hardware Handshaking** : Software Configurable, RTS/CTS
8. **Application Protocols** : Based on license, it is available for all application protocols like IEC60870-5-101, DNP3.0, ModBus, Hitachi, SPA-Bus, and other master or slave protocols.

5.3.2 VC-2DCU12S Specifications

1. **Type of Module** : Plug-in module in Slot2 or Slot3 of main unit
2. **Number of Serial Ports** : 12 serial ports
3. **Serial Port Standards** : Software configurable, RS232 or RS485 for each port per module
4. **Serial Port Speed** : Software configurable per port
300/600/1200/2400/4800/9600/19200/38400/57600 bps
5. **Serial Protocols Mode** : Software configurable per port Asynchronous, Synchronous, SDLC, BiSync mode.
6. **Signal Configurations** : In Async RS232:
TXD/RXD/GND/RTS/CTS signals ready
In Async RS485:
TX/RX/GND signals ready
In Sync RS232:
TXD/RXD/GND/RTS/CTS/TXC/RXC signals ready
In Bisync RS232:
TXD/RXD/GNS/RTS/CTS signals ready
7. **Hardware Handshaking** : Software Configurable, RTS/CTS
8. **Application Protocols** : Based on license, it is available for all application protocols like IEC60870-5-101, DNP3.0, ModBus, Hitachi, SPA-Bus, and other master or slave protocols.

5.3.3 VC-2DCU16A Specifications

1. **Type of Module** : Plug-in module in Slot2 or Slot3 of main unit
2. **Number of Serial Ports** : 16 serial ports
3. **Serial Port Standards** : Software configurable, RS232 or RS485 for each port per module
4. **Serial Port Speed** : Software configurable per port
300/600/1200/2400/4800/9600/19200/38400/57600 bps
5. **Serial Protocols Mode** : It is only in Asynchronous mode.
6. **Signal Configurations** : In Async RS232:
TXD/RXD/GND signals ready
In Async RS485:
TX/RX/GND signals ready
7. **Application Protocols** : Based on license, it is available for all application protocols like IEC60870-5-101, DNP3.0, ModBus, SPA-Bus and other master or slave protocols that can be run in Asynchronous data mode.

5.4 Modem Card

Modem Card is designed in with an intelligent modem which is of intelligent modem unit. Performing in the VC-2DCU system, this serves as the intermediate interface between system and Host Computer or RTU system.

The Modem card that normally used with VC-2DCU is a modem card from V-RTU2000 product series from Veesta World Company. The specification of modem card is here for reference.

Modem card is in two versions of Data Modem VR-2424 model that is compatible standard SCADA modem and VR-2444 model that is Voice+Data SCADA modem.

5.4.1 VR-2424 Data Modem Specifications

1. **Microprocessor** : XA-G49, 24.576MHz
2. **Memory** : 64KB Flash, 2KB SRAM
(Microprocessor included)
3. **Data Rate** : 1200 / 2400 / 9600 BPS
4. **Operation Mode** : Half or Full Duplex
V.23, V.22bis, V.29, Bell 202
2 or 4-Wire Lease Line
5. **Operating Format** : Asynchronous, Binary, Serial
6. **Transmitter Output Level** : Adjustable 0 dBm to -30 dBm in 2dB Steps (600 ohm)
7. **Receiver Input Level** : Adjustable 0 dBm to -42 dBm in 6dB Steps
8. **Digital Interface** : RS-232C
9600 BPS for Protocol Mode
1200, 2400, 9600 BPS for Modem Mode
9. **Isolation**
 - **Input to Phone Line** : DC 1800V
 - **Line to Line (TX to RX)** : AC 1500V

5.4.2 VR-2444 Voice & Data Modem Specifications

1. **Modem Module** : VR-2444, plug-in Module card
VR-2444B, external box with 48VDC power supply
2. **Microprocessor** : 8051 Intel
3. **Memory** : 64KB Flash, 2KB SRAM
(Microprocessor included)
4. **Data Rate** : 300 / 600 BPS
5. **Operation Mode** : Half or Full Duplex
FSK Mode, Center frequency 2760 \pm 240 Hz
4-Wire Lease Line
600 Ω Line Impedance
6. **Operating Format** : Asynchronous, Binary, Serial
7. **Transmitter Output Level** : Adjustable 0 dBm to -20 dBm Adjustable
8. **Digital Interface** : RS-232C,
TXD/RXD/GND signals
9. **Isolation**
 - Input to Phone Line : DC 1800V
 - Line to Line (TX to RX) : AC 1500V
10. **Voice Module Feature** : 10 ~ 2000 Hz Line filter and mixer
Adjustable voice level in mixer separately
600 Ω Line Impedance
4x Wire, TX & RX voice channel output
Compatible with most of old modem, like Hitachi voice and data modem

Chapter 6 - Time Module Specifications

6.1 General

The VC-2DCU device has a special module named as **VC-2DCUGT1** module. Using VC-2DCU with VC-2DCUGT1 time module made a device that is a high capacity flexible timing system designed for use in any application where reliable time information is essential. It is ideal where synchronization of many different output interfaces is required. VC-2DCUGT1 is a “Stratum 1” (Master) standard synchronizing clock by using highly stable constant temperature crystal oscillator to keep it’s time. The time sources come from GPS (UTC) and IRIG-B time code. GPS is of first priority and IRIG-B takes over during the GPS signal is missing. VC-2DCUGT1 provides all popular high time codes of high precision for IEDs, automation device, protection relays, as well as fault & event recorder, also it provides high-precision IRIG-B signal for those secondary time clock.

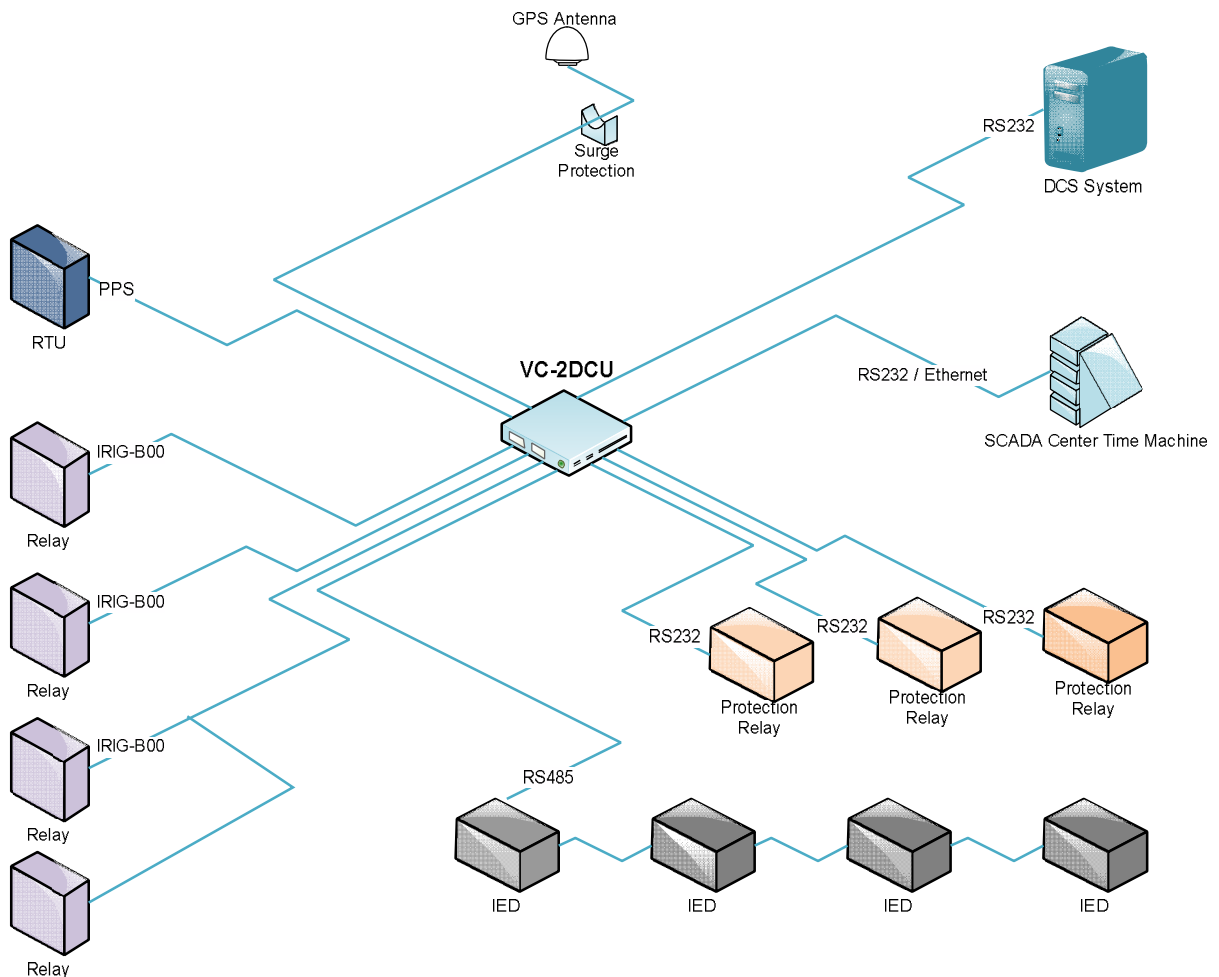

Figure 6-1: VC-2DCU Time System (VC-2DCUGT1 Module) View in action

6.2 Specification

The specification of VC-2DCUGT1 listed as bellow:

6.2.1 Time Module General Characteristics

1. **Time Interfaces** : Time Signal Protocols:
 - 1) IRIG-B output TTL, RS232, RS485 level
 - 2) IRIG-B input TTL, RS232, RS485 level
 - 3) Time Message Output, NMEA, RS232 or RS485 serial port with bit rates 1200, 2400, 4800, 9600, 19200 and 38400 bps software selectable
 - 4) Ethernet port according to NTP

2. **GPS Input** : Receiving frequency: 1575.42MHZ
C/A code (1.023MHz chip rate)
Number of Channels: 12
Connector Type: BNC
GPS antenna feed line length: 10 ~ 180 m

3. **GPS Input Sensitivity** : Antenna radio frequency: Better than -166 dbw
Tracking: Better than -141 dbm
Acquisition: Better than -136 dbm

4. **GPS Acquisition Time** : Hot Start: ≤ 20s
Warm Start: ≤ 40s
Cold Start: ≤ 50s

5. **GPS Time Keeping** : Priority 1: Input via GPS signal
Priority 2: Input via IRIG-B000 TTL Level
Priority 3: Built in Crystal Oscillator
(Accuracy < 1×10^{-8} s)

6.2.2 Time Interface Specifications

1. **IRIG-B Outputs** : Number of Ports: 3 x
TTL Level: Connector BNC3
RS232 Level: Terminal B 1-2
RS485 Level: Terminal B 3-4

2. **Pulse Outputs** : Number of Ports: 2 x
Connector: BNC1, BNC2
Protocols: PPS / PPH / PPM
Output Level: TTL

- 3. **Serial Outputs** : Number of Ports: 4 x
Connector: 8 pin terminal strip
Protocols: NMEA 0183
Baud Rate: 1200/2400/4800/9600/19200/38400 bps
RS232 Level : Terminal A 1-2 & A 5-6
RS485/RS422 Level : Terminal A 3-4 & A 7-8
- 4. **Ethernet Outputs** : Number of Ports: 1-4 (based on network module used)
Connector: RJ45
Protocols: NTP, SNTP
- 5. **IRIG-B Inputs** : Number of Ports: 3 x
TTL Level: Connector BNC4
RS232 Level: Terminal B 5-6
RS485 Level: Terminal B 7-8
- 6. **GPS Input** : GPS Antenna Input
Connector: BNC5
Antenna Cable : 30 meters with fixing accessories
- 7. **Timing Accuracy** : A) Demodulated IRIG-B000: <math><1\mu\text{s}</math> to UTC
B) Pulse Output(TTL): $\leq 0.3\mu\text{s}$ to UTC
C) Serial Protocol (NMEA 0813): <math><200\mu\text{s}</math> to UTC

6.2.3 Antenna Specifications

- 1. **Overall Specification** : Center Frequency: 1575.42 MHz
Gain: 27 dB typically
Noise Figure: 2.0 max
Band Width: 2 MHz min.
Axial Ratio: 3 dB max.
VSWR: 1.5 max
Output Impedance: 50 Ω
- 2. **GPS Antenna Element** : Center Frequency: 1575.42 MHz, ± 1.023 MHz
Polarization: RHCP (Right Hand Circular Polarization)
Absolute Gain at Zenith: +5 dBi typically
Gain at 10 $^{\circ}$ Elevation: -1 dBi typically
Axial Ratio: 3 dB max.
Output VSWR: 1.5 max
Output Impedance: 50 Ω

-
- 3. Antenna Amplifier** : Center Frequency: 1575.42 MHz, ± 1.023 MHz
 Power Gain: 30 dB typical
 Band Width: 2 MHz min.
 Noise Figure: 1.5 max
 Filtering: -20 dB min. @ $F_o \pm 50$ MHz
 Supply Voltage: 4.0~6.0V DC
 Current Consumption: 28mA, ± 3 mA
 VSWR: 1.5 max
 Output Impedance: 50 Ω
- 4. Antenna Mechanical** : Weight (without cable): 220g
 Size: 4.5" X 2.9"
 Cable Type: RG8/U (Other type by order).
 Cable Length: 30m (Other lengths available)
 Connector Options: BNC
 Mounting: Thread permanent mount
- 5. Antenna Environment** : Working Temperature: -40°C ~ +85°C
 Storage Temperature: -50°C ~ +90°C
 Humidity: 95% ~ 100% RH
 Water Proof: 100%
- 6. Lighting Surge Protector** : A) Electrical data
 IEC category / EN type: C2 / C3 / D1
 Highest continuous voltage U_C : 280 VDC/195 VAC
 Nominal current I_N : 5 A (25°C)
 Nominal discharge surge current I_n (8/20) μ s:
 Core-shield/Core-ground: 20 kA / 20 kA
 Total surge current (8/20) μ s: 20 kA 10 kA
 Output voltage limitation at 1 kV/ μ s:
 Core-shield/Core-ground: ≤ 700 V / ≤ 700 V
 Cut-off frequency f_g (3dB) In a 50 Ω system:
 Symmetrical / Asymmetrical - / > 3 GHz
- B) General data
 Temperature range: -40°C ... 80°C
 Degree of protection: IP55
 Connection method: BNC connector 50 Ω
- (It is Optional product must be ordered separately)**

Chapter 7 - Communication Protocols

7.1 General

In VC-2DCU system, we have a wide range of communication protocols, like DNP3.0, IEC 870-5-101, IEC 870-5-104, ModBus RTU, ABB SPA-Bus and etc.

In this chapter you will find protocol definition and profile document of each protocols. For more information please refer to the Software Configuration program user's manual of VC-2DCU system.

7.2 DNP3.0 Profile

In the table bellow you can find DNP3.0 Profile of VC-2DCU product series.

Table 7-1: VC-2DCU, DNP3.0 Device Profile Document

DNP 3.0	
DEVICE PROFILE DOCUMENT	
Vendor Name : Veesta World Company	
Device Name : VC-2DCU (Veesta Data Concentrator Unit)	
Highest DNP Level Supported : For Requests : Level 3 For Responses : Level 3	Device Function : <input checked="" type="checkbox"/> Master <input checked="" type="checkbox"/> Slave
Notable objects, functions, and/or qualifiers supported in addition to the Highest DNP Levels Supported (the complete list is described in the attached table) :	
Maximum Data Link Frame Size (octets) : Transmitted : 292 Received : 292	Maximum Application Fragment Size (octets): Transmitted : 2048 Received : 2048
Maximum Data Link Re-tries : <input type="checkbox"/> None <input type="checkbox"/> Fixed <input checked="" type="checkbox"/> Configurable, range <u> 0 </u> to <u> 10 </u>	Maximum Application Layer Re-tries : <input checked="" type="checkbox"/> None <input type="checkbox"/> Configurable
Required Data Link Layer Confirmation : <input type="checkbox"/> Never <input type="checkbox"/> Always <input type="checkbox"/> Sometimes <input checked="" type="checkbox"/> Configurable (never or always or sometimes)	

DNP 3.0				
DEVICE PROFILE DOCUMENT				
Vendor Name : Veesta World Company				
Device Name : VC-2DCU (Veesta Data Concentrator Unit)				
Required Application Layer Confirmation :				
<input type="checkbox"/> Never <input type="checkbox"/> Always <input checked="" type="checkbox"/> When reporting Event Data <input type="checkbox"/> When sending multi-fragment responses <input type="checkbox"/> Sometimes <input type="checkbox"/> Configurable				
Timeouts while waiting for :				
Data Link Confirm	<input checked="" type="checkbox"/> None	<input type="checkbox"/> Fixed	<input type="checkbox"/> Variable	<input type="checkbox"/> Configurable
Complete Appl. Fragment	<input checked="" type="checkbox"/> None	<input type="checkbox"/> Fixed	<input type="checkbox"/> Variable	<input type="checkbox"/> Configurable
Application Confirm	<input type="checkbox"/> None	<input checked="" type="checkbox"/> Fixed (2S)	<input type="checkbox"/> Variable	<input type="checkbox"/> Configurable
Complete Appl. Response	<input checked="" type="checkbox"/> None	<input type="checkbox"/> Fixed	<input type="checkbox"/> Variable	<input type="checkbox"/> Configurable
Others : (None)				
Sends / Executes Control Operations :				
WRITE Binary Outputs	<input checked="" type="checkbox"/> Never	<input type="checkbox"/> Always	<input type="checkbox"/> Sometimes	<input type="checkbox"/> Configurable
SELECT / OPERATE	<input type="checkbox"/> Never	<input checked="" type="checkbox"/> Always	<input type="checkbox"/> Sometimes	<input type="checkbox"/> Configurable
DIRECT OPERATE	<input type="checkbox"/> Never	<input checked="" type="checkbox"/> Always	<input type="checkbox"/> Sometimes	<input type="checkbox"/> Configurable
DIRECT OPERATE (NO ACK)	<input type="checkbox"/> Never	<input checked="" type="checkbox"/> Always	<input type="checkbox"/> Sometimes	<input type="checkbox"/> Configurable
COUNT > 1	<input checked="" type="checkbox"/> Never	<input type="checkbox"/> Always	<input type="checkbox"/> Sometimes	<input type="checkbox"/> Configurable
Pulse On	<input type="checkbox"/> Never	<input type="checkbox"/> Always	<input checked="" type="checkbox"/> Sometimes	<input type="checkbox"/> Configurable
Pulse Off	<input checked="" type="checkbox"/> Never	<input type="checkbox"/> Always	<input type="checkbox"/> Sometimes	<input type="checkbox"/> Configurable
Latch On	<input type="checkbox"/> Never	<input type="checkbox"/> Always	<input checked="" type="checkbox"/> Sometimes	<input type="checkbox"/> Configurable
Latch Off	<input type="checkbox"/> Never	<input type="checkbox"/> Always	<input checked="" type="checkbox"/> Sometimes	<input type="checkbox"/> Configurable
Queue	<input checked="" type="checkbox"/> Never	<input type="checkbox"/> Always	<input type="checkbox"/> Sometimes	<input type="checkbox"/> Configurable
Clear Queue	<input checked="" type="checkbox"/> Never	<input type="checkbox"/> Always	<input type="checkbox"/> Sometimes	<input type="checkbox"/> Configurable
Trip / Close	<input type="checkbox"/> Never	<input type="checkbox"/> Always	<input checked="" type="checkbox"/> Sometimes	<input type="checkbox"/> Configurable
Reports Binary Input Change Events when no specific variations requested :		Reports time-tagged Binary Input Change Events when no specific variation requested:		
<input type="checkbox"/> Never <input type="checkbox"/> Only time-tagged <input type="checkbox"/> Only non-time-tagged <input checked="" type="checkbox"/> Configurable to send one or the other		<input type="checkbox"/> Never <input type="checkbox"/> Binary Input Change With Time <input type="checkbox"/> Binary Input Change With Relative Time <input checked="" type="checkbox"/> Configurable		
Sends Unsolicited Responses :		Sends Static Data in Unsolicited Responses :		
<input type="checkbox"/> Never <input type="checkbox"/> Configurable <input type="checkbox"/> Only certain objects <input type="checkbox"/> Sometimes <input checked="" type="checkbox"/> ENABLE/DISABLE UNSOLICITED Function codes supported		<input checked="" type="checkbox"/> Never <input type="checkbox"/> When Device Restarts <input type="checkbox"/> When Status Flags Change		

DNP 3.0	
DEVICE PROFILE DOCUMENT	
Vendor Name : Veesta World Company	
Device Name : VC-2DCU (Veesta Data Concentrator Unit)	
Default Counter Object / Variation : <input type="checkbox"/> No Counters Reported <input checked="" type="checkbox"/> Configurable <input type="checkbox"/> Default Object ___ Default Variation __ <input type="checkbox"/> Point-by-point list attached	Counters Roll Over at : <input type="checkbox"/> No Counters Reported <input type="checkbox"/> Configurable <input type="checkbox"/> 16 Bits <input checked="" type="checkbox"/> 32 Bits <input type="checkbox"/> Other Value ___ <input type="checkbox"/> Point-by-point list attached
Sends Multi-Fragment Responses : <input type="checkbox"/> Yes <input checked="" type="checkbox"/> No	

Table 7-2: VC-2DCU, DNP3.0 Interoperability Table

VC-2DCU INTEROPERABILITY TABLE						
OBJECT			REQUEST		RESPONSE	
Obj	Var	Description	Func Codes (dec)	Qual Codes (hex)	Func Codes (dec)	Qual Codes (hex)
1	0	Binary Input – All Variations	1, 22	00,01,06		
1	1	Binary Input	1	00,01,06	129,130	00,01
1	2	Binary Input with Status	1	00,01,06	129,130	00,01
2	0	Binary Input Change – All Variations	1	06,07,08		
2	1	Binary Input Change without Time	1	06,07,08	129,130	17,28
2	2	Binary Input Change with Time	1	06,07,08	129,130	17,28
2	3	Binary Input Change with Relative Time	1	06,07,08	129,130	17,28
10	0	Binary Output – All Variations	1	00,01,06		
10	2	Binary Output Status	1	00,01,06	129,130	00,01
12	1	Control Relay Output Block	3, 4, 5, 6	17,28	129	echo of request
12	2	Pattern Control Block	5, 6	17,28	129	echo of request
12	3	Pattern Mask	5, 6	00,01	129	echo of request

VC-2DCU INTEROPERABILITY TABLE						
OBJECT			REQUEST		RESPONSE	
Obj	Var	Description	Func Codes (dec)	Qual Codes (hex)	Func Codes (dec)	Qual Codes (hex)
20	0	Binary Counter – All Variations	1, 7, 8, 9 10, 22	00,01,06		
20	1	32-Bit Binary Counter	1	00,01,06	129,130	00,01
20	2	16-Bit Binary Counter	1	00,01,06	129,130	00,01
20	3	32-Bit Delta Counter	1	00,01,06	129,130	00,01
20	4	16-Bit Delta Counter	1	00,01,06	129,130	00,01
20	5	32-Bit Binary Counter without Flag	1	00,01,06	129,130	00,01
20	6	16-Bit Binary Counter without Flag	1	00,01,06	129,130	00,01
20	7	32-Bit Delta Counter without Flag	1	00,01,06	129,130	00,01
20	8	16-Bit Delta Counter without Flag	1	00,01,06	129,130	00,01
21	0	Frozen Counter – All Variations	1, 22	00,01,06		
21	1	32-Bit Frozen Counter	1	00,01,06	129,130	00,01
21	2	16-Bit Frozen Counter	1	00,01,06	129,130	00,01
21	3	32-Bit Frozen Delta Counter	1	00,01,06	129,130	00,01
21	4	16-Bit Frozen Delta Counter	1	00,01,06	129,130	00,01
21	9	32-Bit Frozen Counter without Flag	1	00,01,06	129,130	00,01
21	10	16-Bit Frozen Counter without Flag	1	00,01,06	129,130	00,01
22	0	Counter Change Event – All Variations	1	06,07,08		
22	1	32-Bit Counter Change Event without Time	1	06,07,08	129,130	17,28
22	2	16-Bit Counter Change Event without Time	1	06,07,08	129,130	17,28
22	3	32-Bit Delta Counter Change Event without Time	1	06,07,08	129,130	17,28
22	4	16-Bit Delta Counter Change Event without Time	1	06,07,08	129,130	17,28

VC-2DCU INTEROPERABILITY TABLE						
OBJECT			REQUEST		RESPONSE	
Obj	Var	Description	Func Codes (dec)	Qual Codes (hex)	Func Codes (dec)	Qual Codes (hex)
23	0	Frozen Counter Event – All Variations	1	06,07,08		
23	1	32-Bit Frozen Counter Event without Time	1	06,07,08	129,130	17,28
23	2	16-Bit Frozen Counter Event without Time	1	06,07,08	129,130	17,28
23	3	32-Bit Frozen Delta Counter Event without Time	1	06,07,08	129,130	17,28
22	4	16-Bit Frozen Delta Counter Event without Time	1	06,07,08	129,130	17,28
30	0	Analog Input – All Variations	1, 22	00,01,06		
30	1	32-Bit Analog Input	1	00,01,06	129,130	00,01
30	2	16-Bit Analog Input	1	00,01,06	129,130	00,01
30	3	32-Bit Analog Input without Flag	1	00,01,06	129,130	00,01
30	4	16-Bit Analog Input without Flag	1	00,01,06	129,130	00,01
32	0	Analog Change Event – All Variations	1	06,07,08		
32	1	32-Bit Analog Change Event without Time	1	06,07,08	129,130	17,28
32	2	16-Bit Analog Change Event without Time	1	06,07,08	129,130	17,28
40	0	Analog Output – All Variations	1,22	00,01,06		
40	1	32-Bit Analog Output Status	1	00,01,06	129,130	00,01
40	2	16-Bit Analog Output Status	1	00,01,06	129,130	00,01
41	1	32-Bit Analog Output Block	3, 4, 5, 6	17,28	129	echo of request
41	2	16-Bit Analog Output Block	3, 4, 5, 6	17,28	129	echo of request
50	1	Time and Date	1 2	07 07	129	07
51	1	Time and Date CTO			129, 130	07 quantity=1
51	2	Unsynchronized Time and Date CTO			129, 130	07 quantity=1

VC-2DCU INTEROPERABILITY TABLE						
OBJECT			REQUEST		RESPONSE	
Obj	Var	Description	Func Codes (dec)	Qual Codes (hex)	Func Codes (dec)	Qual Codes (hex)
52	1	Time Delay Coarse			129	07 quantity=1
52	2	Time Delay Fine			129	07 quantity=1
60	1	Class 0	1	06		
			20,21,22	06		
60	2	Class 1	1	06,07,08		
			20,21,22	06		
60	3	Class 2	1	06,07,08		
			20,21,22	06		
60	4	Class 3	1	06,07,08		
			20,21,22	06		
80	1	Internal Indications	1	00,01	129	00,01
			2	00		
			2	00		
No Object			13			
No Object			23			
No Object			0		0	

7.3 IEC60870-5-101 / 104 Interoperability

This companion standard presents sets of parameters and alternatives from which subsets have to be selected to implement particular telecontrol systems. Certain parameter values, such as the number of octets in the COMMON ADDRESS of ASDUs represent mutually exclusive alternatives. This means that only one value of the defined parameters is admitted per system. Other parameters, such as the listed set of different process information in command and in monitor direction allow the specification of the complete set or subsets, as appropriate for given applications. This clause summarizes the parameters of the previous clauses to facilitate a suitable selection for a specific application. If a system is composed of equipment stemming from different manufacturers it is necessary that all partners agree on the selected parameters.

The selected parameters should be crossed in the white boxes (simply replace “” with “”).

NOTE: In addition, the full specification of a system may require individual selection of certain parameters for certain parts of the system, such as the individual selection of scaling factors for individually addressable measured values.

7.3.1 Network Configuration

Network-specific parameter

- | | |
|---|---|
| <input checked="" type="checkbox"/> Point-to-point | <input checked="" type="checkbox"/> Multipoint-party line |
| <input checked="" type="checkbox"/> Multiple point-to-point | <input checked="" type="checkbox"/> Multipoint-star |

7.3.2 Link Layer

Network-specific parameter

Frame format FT1.2, single character 1 and the fixed time out interval are used exclusively in this companion standard.

- | | |
|---|---|
| Link transmission procedure | Address field of link |
| <input checked="" type="checkbox"/> Balanced transmission | <input type="checkbox"/> Not present (balanced transmission only) |
| <input checked="" type="checkbox"/> Unbalanced transmission | <input checked="" type="checkbox"/> One octet |
| | <input checked="" type="checkbox"/> Two octets |
| | <input checked="" type="checkbox"/> Structured |
| | <input type="checkbox"/> Unstructured |

Frame length 255 Maximum length L (number of octets)

7.3.3 Application Layer

7.3.3.1 Transmission mode for application data

Mode 1 (Least significant octet first), as defined in clause 4.10 of IEC 870-5-4, is used exclusively in this companion standard.

7.3.3.2 Common address of ASDU

System-specific parameter

- One octet Two octets

7.3.3.3 Information object address

System-specific parameter

- One octet structured
 Two octets unstructured
 Three octets

7.3.3.4 Cause of transmission

System-specific parameter

- One octet Two octets (with originator address)

Selection of standard ASDUs

7.3.3.5 Process information in monitor direction

Station-specific parameter

- | | |
|---|-----------|
| <input checked="" type="checkbox"/> <1>:= Single-point information | M_SP_NA_1 |
| <input checked="" type="checkbox"/> <2>:= Single-point information with time tag | M_SP_TA_1 |
| <input checked="" type="checkbox"/> <3>:= Double-point information | M_DP_NA_1 |
| <input checked="" type="checkbox"/> <4>:= Double-point information with time tag | M_DP_TA_1 |
| <input checked="" type="checkbox"/> <5>:= Step position information | M_ST_NA_1 |
| <input checked="" type="checkbox"/> <6>:= Step position information with time tag | M_ST_TA_1 |
| <input checked="" type="checkbox"/> <7>:= Bitstring of 32 bit | M_BO_NA_1 |
| <input checked="" type="checkbox"/> <8>:= Bitstring of 32 bit with time tag | M_BO_TA_1 |
| <input checked="" type="checkbox"/> <9>:= Measured value, normalized value | M_ME_NA_1 |
| <input checked="" type="checkbox"/> <10>:= Measured value, normalized value with time tag | M_ME_TA_1 |
| <input checked="" type="checkbox"/> <11>:= Measured value, scaled value | M_ME_NB_1 |
| <input checked="" type="checkbox"/> <12>:= Measured value, scaled value with time tag | M_ME_TB_1 |

<input checked="" type="checkbox"/> <13>:= Measured value, short floating point value	M_ME_NC_1
<input checked="" type="checkbox"/> <14>:= Measured value, short floating point value with time tag	M_ME_TC_1
<input checked="" type="checkbox"/> <15>:= Integrated totals	M_IT_NA_1
<input checked="" type="checkbox"/> <16>:= Integrated totals with time tag	M_IT_TA_1
<input type="checkbox"/> <17>:= Event of protection equipment with time tag	M_EP_TA_1
<input type="checkbox"/> <18>:= Packed start events of protection equipment with time tag	M_EP_TB_1
<input type="checkbox"/> <19>:= Packed output circuit information of protection equipment with time tag	M_EP_TC_1
<input type="checkbox"/> <20>:= Packed single-point information with status change detection	M_PS_NA_1
<input checked="" type="checkbox"/> <21>:= Measured value, normalized value without quality descriptor	M_ME_ND_1
<input checked="" type="checkbox"/> <30>:= Single-point information with time tag CP56Time2a	M_SP_TB_1
<input checked="" type="checkbox"/> <31>:= Double-point information with time tag CP56Time2A	M_DP_TB_1
<input checked="" type="checkbox"/> <32>:= Step position information with time tag CP56Time2A	M_ST_TB_1
<input checked="" type="checkbox"/> <33>:= Bitstring of 32 bit with time tag CP56Time2A	M_BO_TB_1
<input checked="" type="checkbox"/> <34>:= Measured value, normalized value with time tag CP56Time2A	M_ME_TD_1
<input checked="" type="checkbox"/> <35>:= Measured value, scaled value with time tag CP56Time2A	M_ME_TE_1
<input checked="" type="checkbox"/> <36>:= Measured value, short floating point value with time tag CP56Time2A	M_ME_TF_1
<input checked="" type="checkbox"/> <37>:= Integrated totals with time tag CP56Time2A	M_IT_TB_1
<input type="checkbox"/> <38>:= Event of protection equipment with time tag CP56Time2A	M_EP_TD_1
<input type="checkbox"/> <39>:= Packed start events of protection equipment with time tag CP56time2A	M_EP_TE_1
<input type="checkbox"/> <40>:= Packed output circuit information of protection equipment with time CP56time2AM_EP_TF_1	

7.3.3.6 Process information in control direction

Station-specific parameter

<input checked="" type="checkbox"/> <45>:= Single command	C_SC_NA_1
<input checked="" type="checkbox"/> <46>:= Double command	C_DC_NA_1
<input checked="" type="checkbox"/> <47>:= Regulating step command	C_RC_NA_1
<input checked="" type="checkbox"/> <48>:= Set point command, normalized value	C_SE_NA_1
<input checked="" type="checkbox"/> <49>:= Set point command, scaled value	C_SE_NB_1
<input checked="" type="checkbox"/> <50>:= Set point command, short floating point value	C_SE_NC_1
<input checked="" type="checkbox"/> <51>:= Bitstring of 32 bit	C_BO_NA_1

7.3.3.7 System information in monitor direction

Station-specific parameter

<input checked="" type="checkbox"/> <70>:= End of initialization	M_EI_NA_1
--	-----------

7.3.3.8 System information in control direction

Station-specific parameter

<input checked="" type="checkbox"/> <100>:= Interrogation command	C_IC_NA_1
<input checked="" type="checkbox"/> <101>:= Counter interrogation command	C_CI_NA_1
<input checked="" type="checkbox"/> <102>:= Read command	C_RD_NA_1
<input checked="" type="checkbox"/> <103>:= Clock synchronization command	C_CS_NA_1
<input checked="" type="checkbox"/> <104>:= Test command	C_TS_NB_1

- | | |
|---|-----------|
| <input checked="" type="checkbox"/> <105>:= Reset process command | C_RP_NC_1 |
| <input type="checkbox"/> <106>:= Delay acquisition command note 1 | C_CD_NA_1 |

7.3.3.9 Parameter in control direction

(station-specific parameter)

- | | |
|--|-----------|
| <input type="checkbox"/> <110>:= Parameter of measured value, normalized value | P_ME_NA_1 |
| <input type="checkbox"/> <111>:= Parameter of measured value, scaled value | P_ME_NB_1 |
| <input type="checkbox"/> <112>:= Parameter of measured value, short floating point value | P_ME_NC_1 |
| <input type="checkbox"/> <113>:= Parameter activation | P_AC_NA_1 |

7.3.3.10 File transfer

(station-specific parameter)

- | | |
|--|-----------|
| <input checked="" type="checkbox"/> <120>:= File ready | F_FR_NA_1 |
| <input checked="" type="checkbox"/> <121>:= Section ready | F_SR_NA_1 |
| <input checked="" type="checkbox"/> <122>:= Call directory, select file, call file, call section | F_SC_NA_1 |
| <input checked="" type="checkbox"/> <123>:= Last section, last segment | F_LS_NA_1 |
| <input checked="" type="checkbox"/> <124>:= Ack file, ack section | F_AF_NA_1 |
| <input checked="" type="checkbox"/> <125>:= Segment | F_SG_NA_1 |
| <input checked="" type="checkbox"/> <126>:= Directory | F_DR_TA_1 |

7.3.4 Basic Application Functions

7.3.4.1 Station initialization

(station-specific parameter)

- Remote initialization

7.3.4.2 General Interrogation

(system- or station-specific parameter)

- | | | |
|--|-----------------------------------|-----------------------------------|
| <input checked="" type="checkbox"/> global | | |
| <input type="checkbox"/> group 1 | <input type="checkbox"/> group 7 | <input type="checkbox"/> group 13 |
| <input type="checkbox"/> group 2 | <input type="checkbox"/> group 8 | <input type="checkbox"/> group 14 |
| <input type="checkbox"/> group 3 | <input type="checkbox"/> group 9 | <input type="checkbox"/> group 15 |
| <input type="checkbox"/> group 4 | <input type="checkbox"/> group 10 | <input type="checkbox"/> group 16 |
| <input type="checkbox"/> group 5 | <input type="checkbox"/> group 11 | |
| <input type="checkbox"/> group 6 | <input type="checkbox"/> group 12 | |

Addresses per group have to be defined

7.3.4.3 Clock synchronization

(station-specific parameter)

- Clock synchronization

7.3.4.4 Command transmission

(object-specific parameter)

- Direct command transmission
- Direct set point command transmission
- Select and execute command
- Select and execute set point command
- C_SE_ACTTERM used note 2
- No additional definition
- Short pulse duration (duration determined by a system parameter in the outstation)
- Long pulse duration (duration determined by a system parameter in the outstation)
- Persistent output

7.3.4.5 Transmission of Integrated totals

(station- or object-specific parameter)

- | | |
|--|---|
| <input checked="" type="checkbox"/> Counter request | <input checked="" type="checkbox"/> General request counter |
| <input checked="" type="checkbox"/> Counter freeze without reset | <input type="checkbox"/> Request counter group 1 |
| <input checked="" type="checkbox"/> Counter freeze with reset | <input type="checkbox"/> Request counter group 2 |
| <input checked="" type="checkbox"/> Counter reset | <input type="checkbox"/> Request counter group 3 |
| | <input type="checkbox"/> Request counter group 4 |

Addresses per group have to be defined

7.3.4.6 Parameter loading

(object-specific parameter)

- Threshold value
- Smoothing factor
- Low limit for transmission of measured value
- High limit for transmission of measured value

7.3.4.7 Parameter activation

(object-specific parameter)

- Act/deact of persistent cyclic or periodic transmission of the addressed object

7.3.4.8 File transfer

(station-specific parameter)

- File transfer in monitor direction
- File transfer in control direction

7.4 MODBUS Protocol

The DCU could support Modbus protocol, in Master and Slave side.

Modbus enables communication among many (approximately 240) devices connected to the same network, for example a system that measures temperature and humidity and communicates the results to DCU. Many of the data types are named from its use in driving relays: a single-bit output is called a coil, and a single-bit input is called a discrete input or a contact.

7.4.1 Communication and devices

Each device intended to communicate using Modbus is given a unique address. In serial and MB+ networks, only the node assigned as the Master may initiate a command. On Ethernet, any device can send out a Modbus command, although usually only one master device does so. A Modbus command contains the Modbus address of the device it is intended for. Only the intended device will act on the command, even though other devices might receive it (an exception is specific broadcastable commands sent to node 0 which are acted on but not acknowledged). All Modbus commands contain checksum information, to ensure a command arrives undamaged. The basic Modbus commands can instruct an RTU to change a value in one of its registers, control or read an I/O port, as well as command the device to send back one or more values contained in its registers.

7.4.2 Frame Format

The bellow frame format can be support in Modbus protocol of DCU:

- Modbus RTU frame format
- Modbus ASCII frame format
- Modbus TCP frame format

7.4.3 Supported Function Codes

The various reading, writing and other operations are categorized as follows. The most primitive reads and writes are shown in bold. A number of sources use alternative terminology, for example Force Single Coil where the standard uses Write Single Coil.

Please refer to the table bellow for supported function codes:

Modbus Supported Function Codes				
Function type			Function name	Function code
Data Access	Bit access	Physical Discrete Inputs	Read Discrete Inputs	2
		Internal Bits or Physical Coils	Read Coils	1
			Write Single Coil	5
			Write Multiple Coils	15
	16-bit access	Physical Input Registers	Read Input Registers	4
		Internal Registers or Physical Output Registers	Read Holding Registers	3
			Write Single Register	6
			Write Multiple Registers	16
			Read/Write Multiple Registers	23
			Mask Write Register	22
			Read FIFO Queue	24
			File Record Access	Read File Record
	Write File Record	21		
	Diagnostics			Read Exception Status
		Diagnostic	8	
		Get Com Event Counter	11	
		Get Com Event Log	12	
		Report Slave ID	17	
		Read Device Identification	43	
Other			Encapsulated Interface Transport	43

7.4.4 Implementations

Almost all implementations have variations from the official standard. Different varieties might not communicate correctly between equipment of different suppliers. Some of the most common variations are:

7.4.4.1 Data types

- Floating point IEEE
- 32-bit integer
- 8-bit data
- Mixed data types
- Bit fields in integers
- Multipliers to change data to/from integer. 10, 100, 1000, 256 ...

7.4.4.2 Protocol extensions

- 16-bit slave addresses
- 32-bit data size (1 address = 32 bits of data returned.)
- Word swapped data

7.5 Hitachi HC4300 Protocol

The VC-2DCU could support Hitachi protocol, in Master and Slave side.

In fact there is not profile list configurable for Hitachi protocol. Therefore the complying support to this protocol is well enough in this chapter.

7.6 INDACTIC 2033 Protocol

Indactic 2033 is part of Indactic 33 Telecommunication system from ABB. The VC-2DCU could support Indactic 2033 protocol in Slave side.

7.6.1 Network Configuration

- 1. Point to Point** : Only 1 RTU
- 2. Star Network** : One Channel to each RTU
- 3. Addressing** : Configurable in the range

7.6.2 Telecommunications

- 1. Transmission Mode** : Pseudohalfduplex and real halfduplex
- 2. Receiving** : Synchronous for pseudohalfduplex
Asynchronous (start/stop) for halfduplex
- 3. Sending** : Asynchronous (start/stop)
- 4. Security** : Hamming Distance 4
- 5. Word Length** : 16 bits for standard telegrams
8 and/or 12 bit for CRC-8 coded measurand
- 6. Data Rate** : 50, 100, 300, 600, 1200, 2400 baud

7.6.3 Commands

- 1. Number of outputs** : Up to 1920 contact totals
- 2. Command Type** : 1- Pulse command
2- Regulating command
3- Permanent command

7.6.4 Setpoints

- 1. Number of outputs** : Up to 240 bytes
- 2. Cyclic Setpoints** : Up to 16 bytes

7.6.5 Change of State Indications

- 1. Number of Inputs** : Up to 1920 contacts total
- 2. Storage capacity** : Configurable from 250 events up to 2000 events

7.6.6 Counters

- 1. Number of inputs** : Up to 64 counters of 3 bytes each
- 2. Counting mode** : 6 digit BCD or 24 bit binary

7.6.7 Measurands

- 1. Number of inputs** : Up to 128 bytes
- 2. Transmission mode** : Configurable per file for Standard Indactive 33 or CRC-8
- 3. Size of measurands** : 8 or 16 bits, selectable per file

7.7 ABB SPA-Bus Protocol

The SPA-Bus is, was originally designed as a fieldbus in a distributed protection, control and event reporting system.

The SPA-Bus uses an asynchronous serial communications protocol (1 start bit, 7 data bits + even parity, 1 stop bit) with data transfer rate of 9600 b/s. (In some cases a rate of 300, 1200, 2400 or 4800 bit/s can also be used). Messages on the bus consist of ASCII characters. The bus can support one master and several slaves.

VC-2DCU support SPA-Bus protocol V2.5 within file transfer for configuration files.

7.8 Other Protocols

Information of other protocols like ELCOM90, M-Bus, ABB PN40 and etc, is available by request.

Chapter 8 - Installation & Connections

8.1 Overview

In this chapter we describe about each installation and connections of VC-2DCU that based on purpose of usage you can select desired system configuration.

For Installation of VC-2DCU in any side and purpose bellow main steps must be considered.

- Power Supply source voltage.
- Network connections over LAN.
- Communication serial type.
- Protocols as slave or master devices.
- List of slave device point information, like tags, addresses, ...
- List of master device information and point database
- Configuration VC-2DCU, with integrated software

8.2 VC-2DCUMU1 Model

8.2.1 Power Supply Source

During configuration of any system by VC-2DCUMU1, you must define what power source is. For example in V-RTU2000 system, power source is normally 48VDC system. So connection of power source to the back plane of VC-2DCUMU1 must be from DC terminal. Or you may install VC-2DCUMU1 in control center with normally AC 200V power source so connection of AC power must be used, or you may have two combinations of them. In Figure 8-1 you can find detail information of connection diagram of power sources.

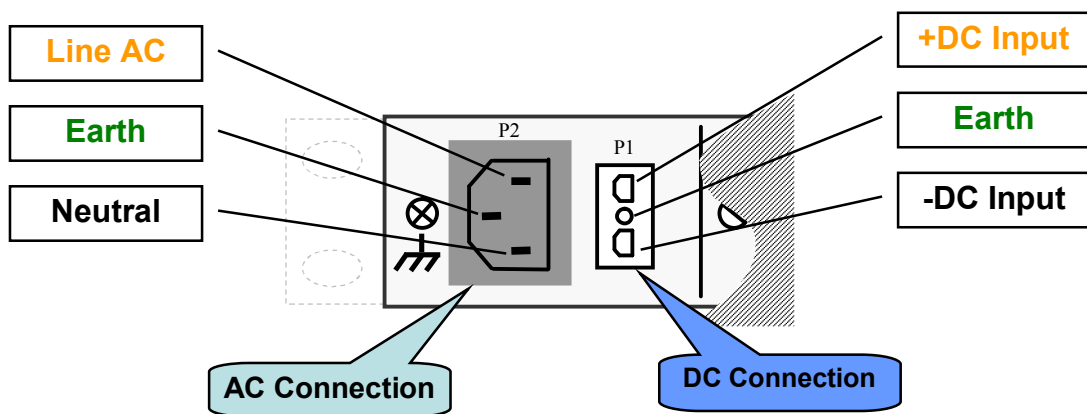
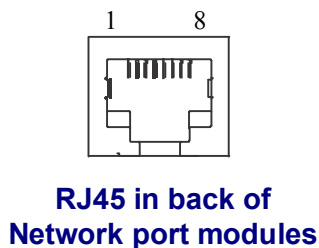

Figure 8-1: VC-2DCUMU1, Power Source, Connection Wiring

8.2.2 Ethernet Ports

This Type of port can be used for LAN network data. The connection of RJ45 for network module has been used for this type of port by RJ45 connector. The type of Ethernet can be used only in Network Service modules that have been installed over Slot #1.

In the Figure 8-2 you can see detail information based on pin-out of connections.



PIN	Description
1	TX+: Transmit Data +
2	TX-: Transmit Data -
3	RX+: Received Data +
4	-
5	-
6	RX-: Received Data -
7	-
8	-

Figure 8-2: VC-2DCUMU1, Ethernet Port, Connection Wiring

8.2.3 Mode of Simple RS232 Ports

This Type of port only send/receive signals of RS-232C standards. It is simple serial communication between VC-2DCUMU1 and device. It is a serial device port by RJ45 connection type. In the Figure 8-3 you can see detail information based on pin-out of connections.

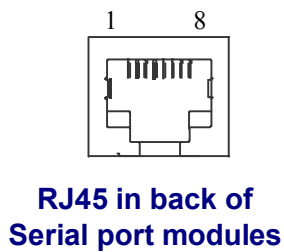

PIN	Description
1	-
2	RxD: Receive Data (←)
3	TxD: Transmit Data (→)
4	-
5	Signal Ground
6	-
7	-
8	-

Figure 8-3: VC-2DCUMU1, Serial Port, RS232 Simple Connection Wiring

8.2.4 Mode of RS-232 + Flow Control

This Type of port has hardware flow control signals of RS-232C standards. It is a serial device port by RJ45 connection type. In the Figure 8-4 you can see detail information based on pin-out of connections.

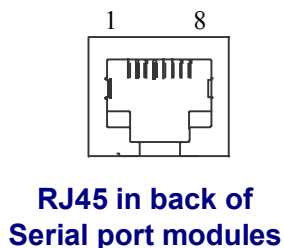

PIN	Description
1	-
2	RxD: Receive Data (←)
3	TxD: Transmit Data (→)
4	-
5	Signal Ground
6	-
7	RTS: Request To Send
8	CTS: Clear To Send

Figure 8-4: VC-2DCUMU1, Serial Port, RS232+Flow Control Connection Wiring

8.2.5 Mode of RS-232 + Clock Signal

This Type of port can be used in asynchronous and synchronous of serial connections of RS-232C standards. In additionally to communicate some old modems it also support transmit and receive clock signal. It is a serial device port by RJ45 connection type. In the Figure 8-5 you can see detail information based on pin-out of connections.

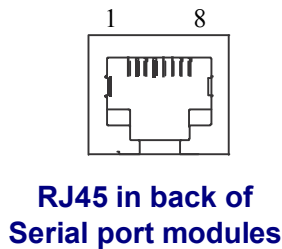

PIN	Description
1	-
2	RxD: Receive Data (←)
3	TxD: Transmit Data (→)
4	TXC: Clock of Transmitter
5	Signal Ground
6	RXC: Clock for Receiver
7	-
8	-

Figure 8-5: VC-2DCUMU1, Serial Port, RS232+Clock Signals Connection Wiring

8.2.6 Mode of RS-232 + Clock Signal + Flow Control

This Type of port can be used in asynchronous and synchronous of serial connections of RS-232C standards. In additionally to communicate some old modems it also support transmit and receive clock signal. If you want to use from hardware handshaking, you can use from RTS/CTS signals also. It is a serial device port by RJ45 connection type. In the Figure 8-6 you can see detail information based on pin-out of connections.

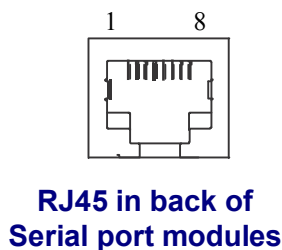

PIN	Description
1	-
2	RxD: Receive Data (←)
3	TxD: Transmit Data (→)
4	TXC: Clock of Transmitter
5	Signal Ground
6	RXC: Clock for Receiver
7	RTS: Request To Send
8	CTS: Clear To Send

Figure 8-6: VC-2DCUMU1, Serial Port, RS232+Clock+Flow Control Wiring

8.2.7 Mode of RS-485

This Type of port can be used for networked serial data, such as RS-485 network standard. It is a serial device port by RJ45 connection type. In the Figure 8-7 you can see detail information based on pin-out of connections.

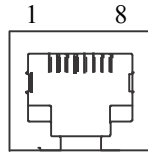

**RJ45 in back of
Serial port modules**

PIN	Description
1	-
2	-
3	A (D+) : Data of RS485
4	-
5	System Ground (If need)
6	-
7	B (D-) : Data of RS485
8	-

Figure 8-7: VC-2DCUMU1, Serial Port, RS485 Connection Wiring

8.3 VC-2DCUMU2 Model

8.3.1 Power Supply Source

During configuration of any system by VC-2DCUMU2, you must define what power source is. In Figure 8-8 you can find detail information of connection diagram of power sources.

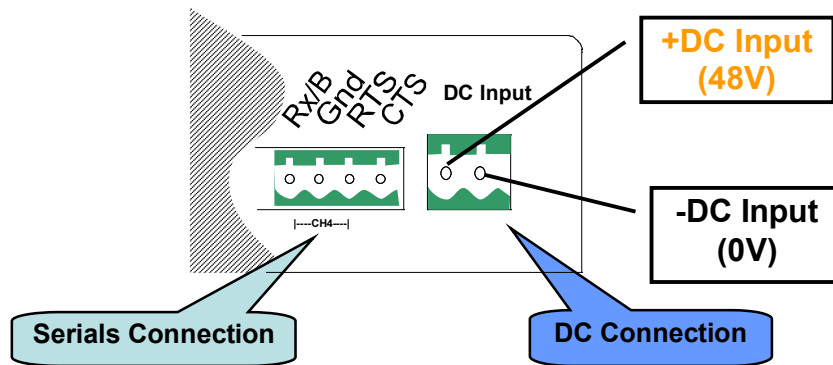
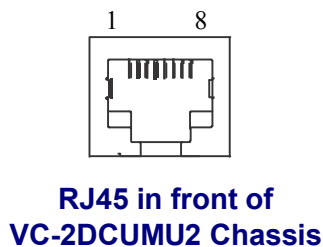

Figure 8-8: VC-2DCUMU2, Power Source, Connection Wiring

8.3.2 Ethernet Ports

This Type of port can be used for LAN network data. The connection of RJ45 for network module has been used for this type of port by RJ45 connector. The Ethernet port can be found in the front panel of VC-2DCUMU2 chassis.

In the Figure 8-9 you can see detail information based on pin-out of connections.



PIN	Description
1	TX+: Transmit Data +
2	TX-: Transmit Data -
3	RX+: Received Data +
4	-
5	-
6	RX-: Received Data -
7	-
8	-

Figure 8-9: VC-2DCUMU2, Ethernet Port, Connection Wiring

8.3.3 Mode of Simple RS232

This Type of port only send/receive signals of RS-232C standards. It is simple serial communication between VC-2DCUMU2 and device. It is a serial device port by socket connector in the back panel of chassis of VC-2DCUMU2. Each communication ports tagged as CH1~CH4 so the wiring of each port has repeated tags that has been shown in Figure 8-10 as pin-out of connections.

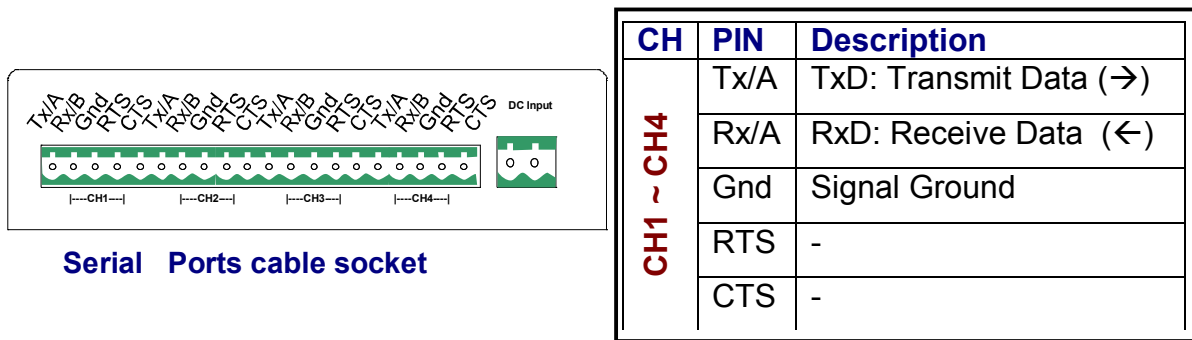

Figure 8-10: VC-2DCUMU2, Serial Port, RS232 Simple Connection Wiring

8.3.4 Mode of RS-232 + Flow Control

This Type of port has hardware flow control signals of RS-232C standards. It is a serial device port by CH1-CH4 in back panel of device chassis by a cable socket connector. In the Figure 8-11 you can see detail information based on pin-out of connections.

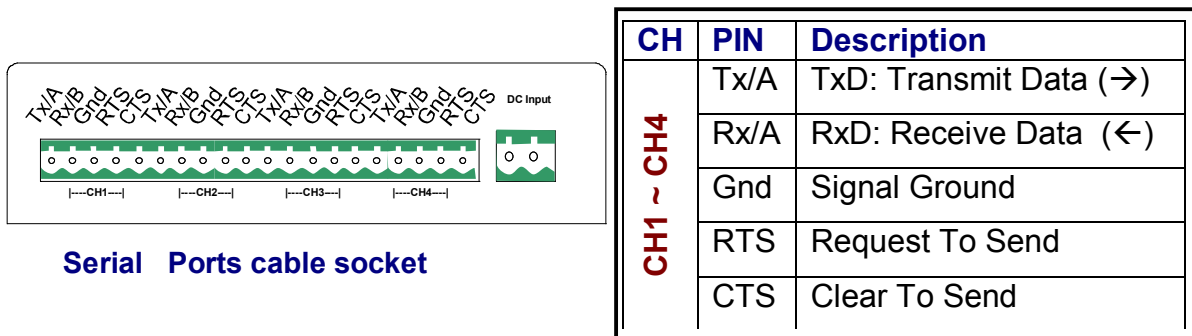

Figure 8-11: VC-2DCUMU2, Serial Port, RS232+Flow Control Connection Wiring

8.3.5 Mode of RS-485

This Type of port can be used for networked serial data, such as RS-485 network standard. It is a serial device port by socket connector in the back panel of VC-2DCUMU2 device. In the Figure 8-12 you can see detail information based on pin-out of connections.

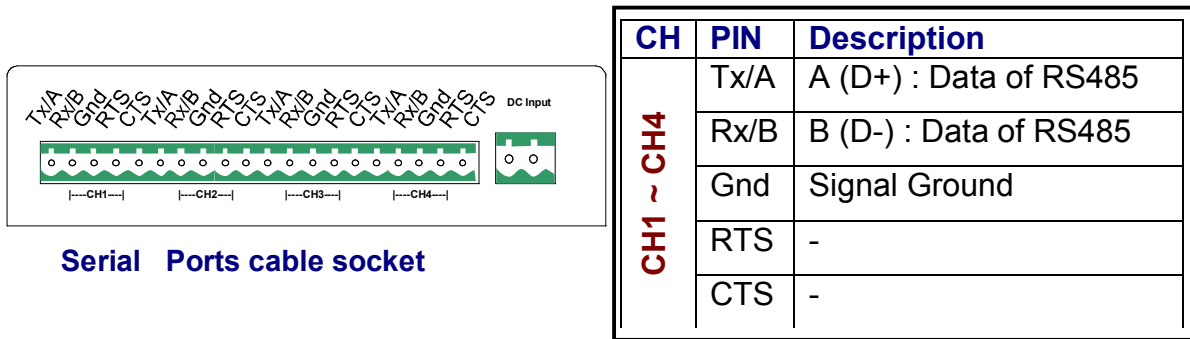
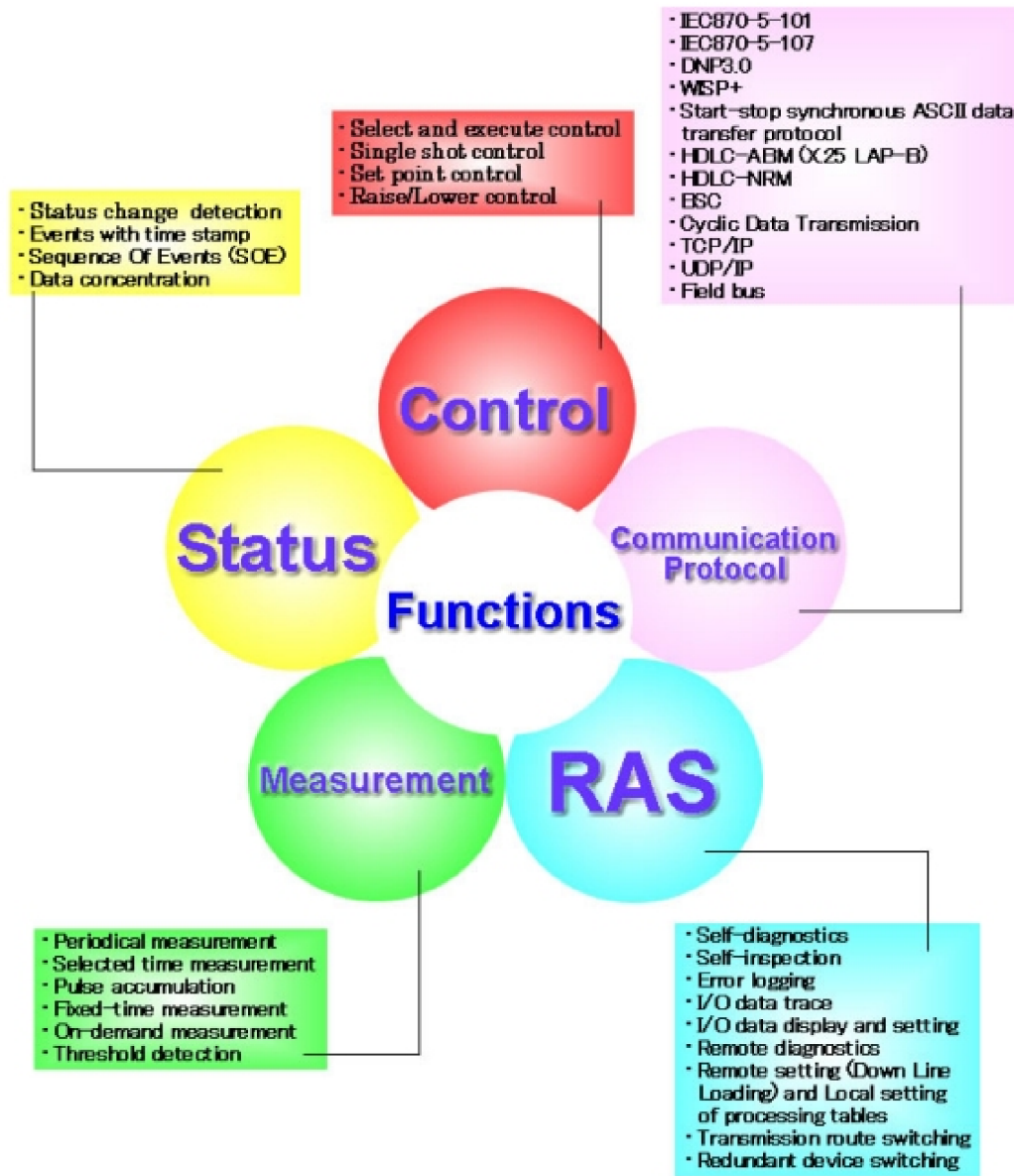

Figure 8-12: VC-2DCUMU2, Serial Port, RS485 Connection Wiring



Veesta World Co
 World Wide Web: <http://www.veesta-world.com/>
 E-Mail: info@veesta-world.com